



PT. SURYA TAMA MEDIKA
MEDICAL HOSPITAL SUPPLY • REPAIR AND SERVICE

Nomor : 081/STM-OPT/III/2020
Perihal : Penawaran harga

Kepada Yth. :

Direktur Rs. Mata Undaan

Jl. Undaan Kulon No.19, Peneleh, Kec. Genteng, Kota SBY, Jawa Timur 60274.

Dengan hormat,

Kami PT. Surya Tama Medika bermaksud mengajukan penawaran harga untuk alat-alat kedokteran Poli Mata sebagai berikut :

No	Nama Alat	Type, Merk	Price List	Discount 20%	Total
1	LED Slit Lamp Microscope with TD 10 Digital Camera System	700 GL + TD 10, Takagi-Seiko, Japan	Rp. 425.370.000,-	Rp. 85.074.000,-	Rp. 340.296.000,-
2	LED Slit Lamp Microscope with TD 10 Digital Camera System	2 ZL + TD 10, Takagi-Seiko, Japan	Rp. 295.000.000,-	Rp. 59.000.000,-	Rp. 236.000.000,-

Syarat & Ketentuan :

- Penawaran ini berlaku selama 30 hari kerja, lebih dari itu mohon konfirmasi kembali kepada kami;
- Harga tidak terikat dan sewaktu-waktu dapat berubah tanpa pemberitahuan terlebih dahulu;
- **Harga belum termasuk PPN 10%;**
- **Harga belum termasuk ongkos kirim, instalasi, training alat;**
- Garansi 1 tahun yang bukan disebabkan oleh kesalahan pemakai;
- Cara pembayaran : Uang muka 50%, Sisa Pembayaran dibayarkan setelah barang diterima.

Spesifikasi terlampir

Demikian surat penawaran ini kami sampaikan sebagai bahan pertimbangan Bapak/Ibu. Atas perhatiannya kami ucapkan terima kasih.

Bekasi, 19 Maret 2020

Hormat kami,

Rossi
08165415819

Jl. Mayor Hasibuan, Ruko Suncity Square Blok E27, Bekasi – West Java, Indonesia 17141

Tel. +62 21 8886 3658 Fax. +62 21 8886 3658

Email: suryatamamedika@yahoo.co.id



Spesifikasi Alat :

1. LED Slit lamp Microscope 700GL With TD-10 Digital Camera System

Type : 700 GL + TD10

Brand : Takagi Seiko, Japan

Features :

1. Innovative Design without a cable

- Innovative Design : No cables are exposed. Even power supply cable is concealed .
- Discontinuance of the power supply cable from the chinrest to the lamp house.
- Power of the conventional slit lamps was supplied from the chin rest to the lamp housing. 700GL looks neat and compact with minimized cable with no possible failure.
- Even cables for connecting an imaging system can be concealed. . Renewed product Color

2. LED

LED Optimized New Slit Lamp

- The best advantage of the LED light source is that the affected parts which used to be difficult to be seen with the conventional light sources can be more clearly seen.
- Our LED slit lamp is not a type of exchanging the halogen unit, but a completely new model that adopts a dedicated LED light source.
- The LED optimized slit lamp provides brighter and sharper light. Use of Uniform LED Illumination
- The LED slit lamp with a color temperature of 3500 K provides brighter and sharper light than halogen.
- A 1-element high-luminance LED is used for the slit lamp. It provides uniform and even light compared to the 4 element LEDs. Reduction of the Characteristic Blue Light of LED
- The projected light is soft and easy on patients' eyes by reducing the peak of the characteristic blue band spectrum of LED

3. Optical Design

Expert in both observations of the anterior and posterior segments of the eye

- Working toward improvement of visibility during fundus observation and realization of anterior segment observation comparable to conventional devices as critical factors, the world's foremost brightness and sharp optical design is realized.
- 700GL's binocular tubes with a 6-degree convergence provide easy binocular fusion, ensuring stress-free observation.

4. Use of Uniform LED Illumination

- The LED slit lamp with a color temperature of 3500 K provides brighter and sharper light than halogen.
- A 1-element high-luminance LED is used for the slit lamp. It provides uniform and even light compared to the 4 element LEDs



5. Reduction of the Characteristic Blue Light of LED

- The projected light is soft and easy on patients' eyes by reducing the peak of the characteristic blue band spectrum of LED.

6. Extended Slit Length

- The diameter of the slit length is extended to 14mm from 10mm. This allows 700GL to illuminate a wider area of the anterior segment.
- This allows 700GL to maximize its characteristics such as a wider field of view.

Microscope

Type	Galilean converging binocular stereomicroscope
Magnification changer	Five position rotating drum
Eyepieces	16x wide-field, high-eyepoint
Total magnifications	6.3x, 10x, 16x, 25x, 40x
Real fields of view	φ35.9, φ23.3, φ14, φ8.8, φ5.5mm
Interpupillary adjustment	52 - 82mm
Diopter adjustment range	+/-7diopters
Longitudinal (coarse) movement	105mm
Cross-Slide Base	
Horizontal (fine) movement	15mm
Vertical movement	30mm
Chinrest Unit	
Elevation stroke	85mm
Slit width	0-14mm continuously variable
Illumination Unit	
Aperture diaphragms	φ14, φ10, φ5, φ3, φ2, φ1, φ0.2mm
Filters	Blue filter, Red free filter, Blue correction filter, Yellow filter
Light Source	LED
Input voltage	AC100V - 240V (+/- 10%)
Power Unit	
Maximum power consumption	DC5V 2A
Fixation Light Unit	
Fixation light source	Red LED
Weight	13.3 kg



With CCTV / Imaging System

Type : TD 10
Merk : Takagi Seiko, Japan

Use of Ultra High Resolution 10.7 Mega Pixel Camera

Use of Ultra High Resolution 10.7 Mega Pixel Camera with 3856 x 2764 picture size, delivering 7.4 times higher-resolution compared to the previous digital camera of TD-1plus.

USB 3.0 Connection Interface

By changing to the new USB 3.0 interface, data transfer speed is now approximately 6.4 times faster than that of the previous IEEE1394b fire-wire interface. Stress-free high-resolution live images are made possible.

User Friendly Software with DICOM Compatibility

User friendly software with patient database, full image editing facility, and DICOM compatibility.

1. Neat Digital Imaging System with hidden cables

In combination with our LED slit lamps minimum cables for TD-10 are exposed as they can be quickly and neatly concealed in the slit lamp's arm..

2. Yellow Filter Built in as Standard

High-contrast images are easily obtained by using the built-in yellow filter for corneal fluorescein observation. In conjunction with our slit lamps cobalt blue filter even higher-contrast images can be achieved.

3. Capturing of Still Images with One Push

In combination with our supplied trigger cable, still images can be captured instantly and conveniently by pressing the joystick button of the slit lamp. Captured images can be displayed as thumbnail images in the lower part of the screen for evaluation.

4. New EyeCAM Main Screen Design

The conventional image filing software & patient database have been further upgraded for more ease of use and intuitive handling by reviewing each icon while maintaining the convenient functionality.

5. Easy Capture with Six Pre-stored Eye Settings

Setting of the digital camera can be changed and saved easily with six types of scene files according to the eye condition and image type required. Use our presaved recommended settings or simply adjust each pre-set to your own desired level for very fast and convenient high quality image acquisition.

6. Convenient Comparison Functions for Follow-up

Observations

Newly captured images and images taken in past examinations can be displayed on the same screen. Up to six images can be displayed and compared at once.

7. Combination with background illumination system

In combination with our background illumination device, a more comprehensive explanation is made possible to the patient.

* Back ground illumination built in as standard with 700GL and 4ZL models



8. Slitlamp models compatible with TD-10 types

Type GZL : 700GL, 2ZL, 4ZL
Type XL : 300XL

Camera specifications

Picture size : 3856×2764
Resolution depth : 12bit
Digital interface : USB 3.0
Frame Rate : 7.3fps
Electricity Consumption : 4.5W以下

System Requirements

OS : Windows 7 & 8, 64bit (All Editions)
RAM : 4GB or more recommended
Interface : USB 3.0
CPU : Intel I5 or superior CPU recommended

Consist of :

- 1 Unit Slit Lamp
- 1 Unit Electric Table
- 1 Unit Digital Imaging System (TD10)
- 1 Unit PC All In One



2. LED Slit lamp Microscope 2 ZL With TD-10 Digital Camera System

Type : 2 ZL + TD 10

Brand : Takagi Seiko, Japan

Features :

Innovative Design

- Innovative Design : No cables are exposed. Even the power supply cable is concealed.
- Even cables for connecting an imaging system can be concealed.
- New product color.

New LED Optimized Slit Lamp

- One of the best advantages of LED illumination is that affected anatomy and structures of the eye can now be more clearly and visibly seen because the peak wavelength of LED light appears in the region which is more sensitive to the human eye.
- We haven't simply replaced the halogen light source with an LED type. 2ZL has been designed and engineered from scratch to accommodate the new superior LED lamp.
- LED optimized 2ZL provides brighter and sharper light.

Use of Uniform LED Illumination

- The LED slit lamp with a color temperature of 3500 K provides brighter and sharper light than halogen.
- A 1-element high-luminance LED is used for 2ZL. It provides uniform and even light compared to multiple element LEDs.

Reduction of the Characteristic

Blue Light of LED

- The projected light is soft and easy on patients' eyes by reducing the peak of the characteristic blue band spectrum of LED.

Use of Ultra-low Voltage LED

- Even though a 3-watt ultra-low voltage LED is used for 2ZL, the LED slit lamp is extremely economical while obtaining a very high level of illumination.

Affordable Precision and Reliability

- 2ZL delivers ease of use at an affordable price with ergonomic handling.
- Focussed on essential features with no compromise to our trademark precision and reliability.



Reduction of Patient's Uneasiness

- When 2ZL is switched on, a circular blue LED lights up around the lower part of the slit unit, which does not disturb the examination. The blue LED light is associated with mental calmness, reducing patient's uneasiness.
- Because the circular blue LED indicates the power is on, the users can examine with 2ZL at ease.

Specifications :

Microscope

Type	: Galilean converging binocular stereomicroscope
Magnification changer	: Three position rotating drum
Eyepieces	: 16x wide-field, high-eyepoint
Total magnifications	: 10x, 16x, 25x
Real fields of view	: ϕ 23.3, ϕ 14, ϕ 8.8mm
Interpupillary adjustment	: 52 - 82mm
Diopter adjustment range	: +/-7diopters

Cross-Slide Base

Longitudinal (coarse) movement	: 105mm
Horizontal (fine) movement	: 15mm
Vertical movement	: 30mm

Chinrest Unit

: Elevation stroke:85mm

Illumination Unit

Slit width	: 0-14mm continuously variable
Aperture	: ϕ 14, ϕ 8, ϕ 5, ϕ 3, ϕ 0.3mm
Aperture diaphragms	
Filters	: Blue filter, Red free filter, Blue correction filter, Yellow filter
Light Source	: LED

Power Unit

Input voltage	: AC100V - 240V (+/- 10%)
Maximum power consumption	: DC5V 2A

Fixation Light Unit

Fixation light source	: Red LED
Weight	: 11 Kg



With CCTV / Imaging System

Type : TD 10
Merk : Takagi Seiko, Japan

Use of Ultra High Resolution 10.7 Mega Pixel Camera

Use of Ultra High Resolution 10.7 Mega Pixel Camera with 3856 x 2764 picture size, delivering 7.4 times higher-resolution compared to the previous digital camera of TD-1plus.

USB 3.0 Connection Interface

By changing to the new USB 3.0 interface, data transfer speed is now approximately 6.4 times faster than that of the previous IEEE1394b fire-wire interface. Stress-free high-resolution live images are made possible.

User Friendly Software with DICOM Compatibility

User friendly software with patient database, full image editing facility, and DICOM compatibility.

8. Neat Digital Imaging System with hidden cables

In combination with our LED slit lamps minimum cables for TD-10 are exposed as they can be quickly and neatly concealed in the slit lamp's arm..

9. Yellow Filter Built in as Standard

High-contrast images are easily obtained by using the built-in yellow filter for corneal fluorescein observation. In conjunction with our slit lamps cobalt blue filter even higher-contrast images can be achieved.

10. Capturing of Still Images with One Push

In combination with our supplied trigger cable, still images can be captured instantly and conveniently by pressing the joystick button of the slit lamp. Captured images can be displayed as thumbnail images in the lower part of the screen for evaluation.

11. New EyeCAM Main Screen Design

The conventional image filing software & patient database have been further upgraded for more ease of use and intuitive handling by reviewing each icon while maintaining the convenient functionality.

12. Easy Capture with Six Pre-stored Eye Settings

Setting of the digital camera can be changed and saved easily with six types of scene files according to the eye condition and image type required. Use our presaved recommended settings or simply adjust each pre-set to your own desired level for very fast and convenient high quality image acquisition.

13. Convenient Comparison Functions for Follow-up

Observations

Newly captured images and images taken in past examinations can be displayed on the same screen. Up to six images can be displayed and compared at once.

14. Combination with background illumination system

In combination with our background illumination device, a more comprehensive explanation is made possible to the patient.

* Back ground illumination built in as standard with 700GL and 42L models



8. Slitlamp models compatible with TD-10 types

Type GZL : 700GL, 22L, 4ZL
Type XL : 300XL

Camera specifications

Picture size : 3856×2764
Resolution depth : 12bit
Digital interface : USB 3.0
Frame Rate : 7.3fps
Electricity Consumption : 4.5W以下

System Requirements

OS : Windows 7 & 8, 64bit (All Editions)
RAM : 4GB or more recommended
Interface : USB 3.0
CPU : Intel i5 or superior CPU recommended

Consist of :

- 1 Unit Slit Lamp
- 1 Unit Electric Table
- 1 Unit Digital Imaging System (TD10)
- 1 Unit PC All In One

Five-position rotating drum	Three-position rotating drum
16x wide-field, high-eyepoint	10x, 16x, 25x
6.3x, 10x, 16x, 25x, 40x	23.3mm, 141mm, 83.8mm
35.9mm, 23.3mm, 141mm, 83.8mm, 5mm	
52 - 82mm	
+/- 7 diopters	
105mm	
15mm	
30mm	
95mm	
0-14mm continuously variable	
1 ϕ 14, ϕ 6, ϕ 5, ϕ 3, ϕ 1, ϕ 0.3mm	
Blue filter, Red line filter, Blue correction filter, Yellow filter	
LED	
AC100V - 240V (+/- 10%)	
DC5V/2A	
Red LED	
Built-in	Not equipped
11.5kg	1.1kg

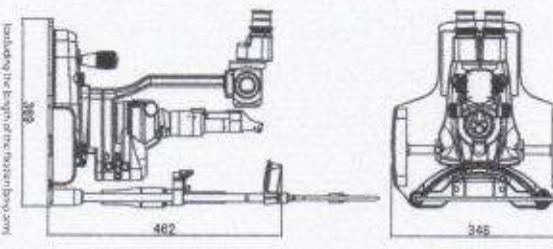

OPTICS

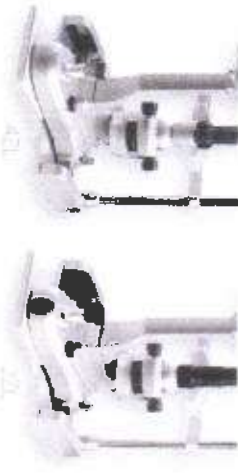
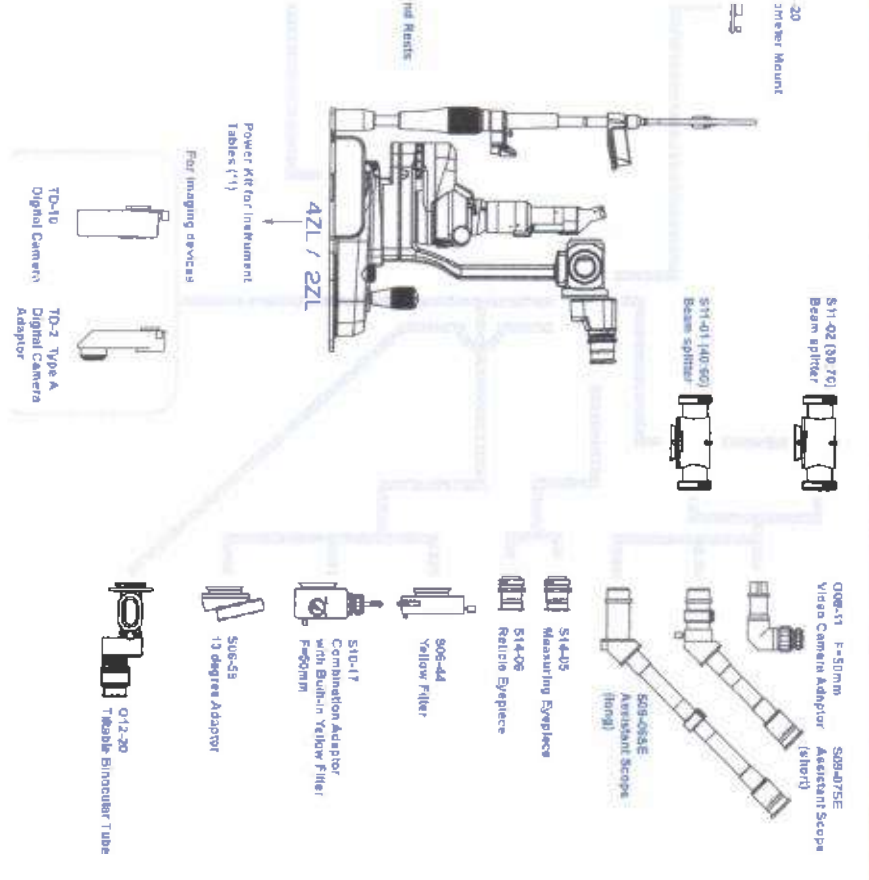

Serving your v

4ZL

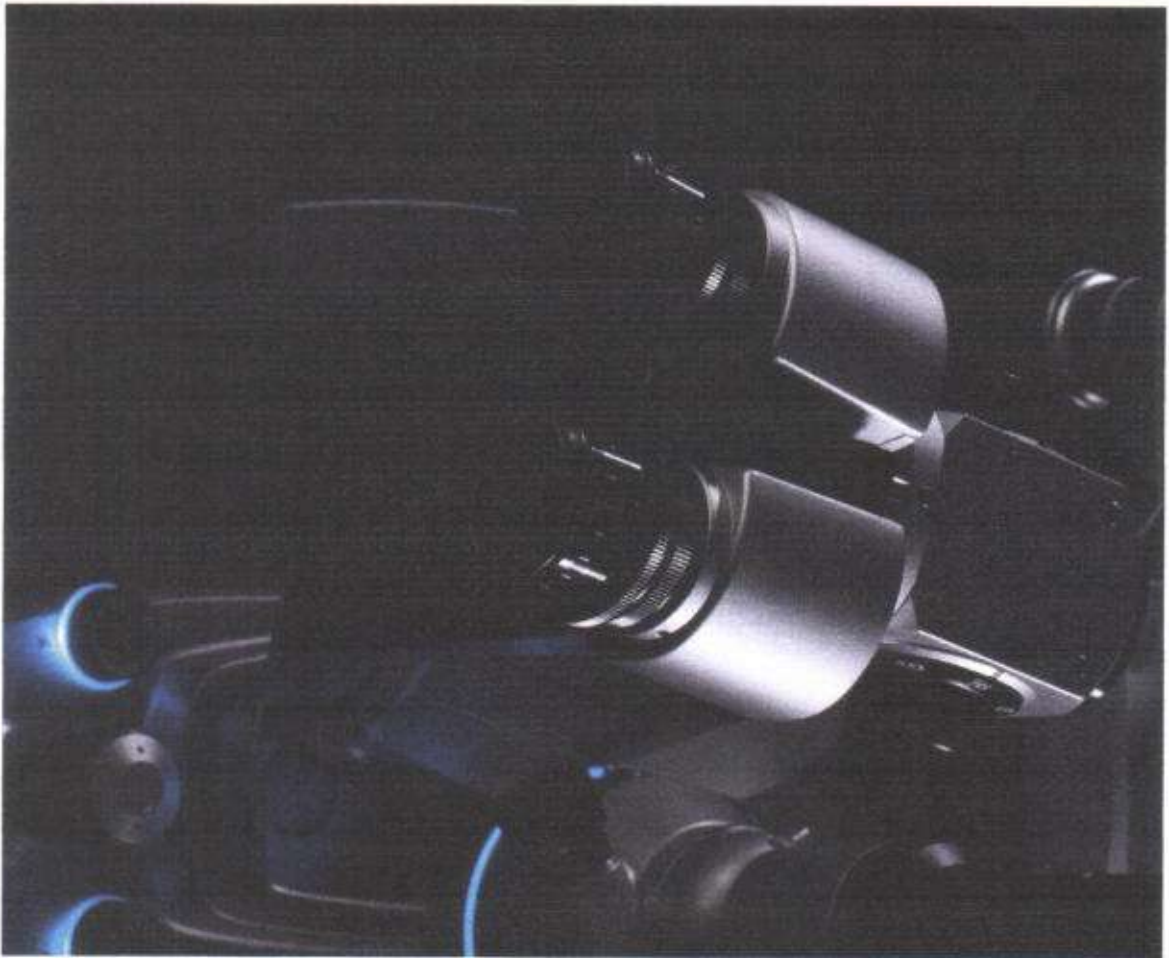

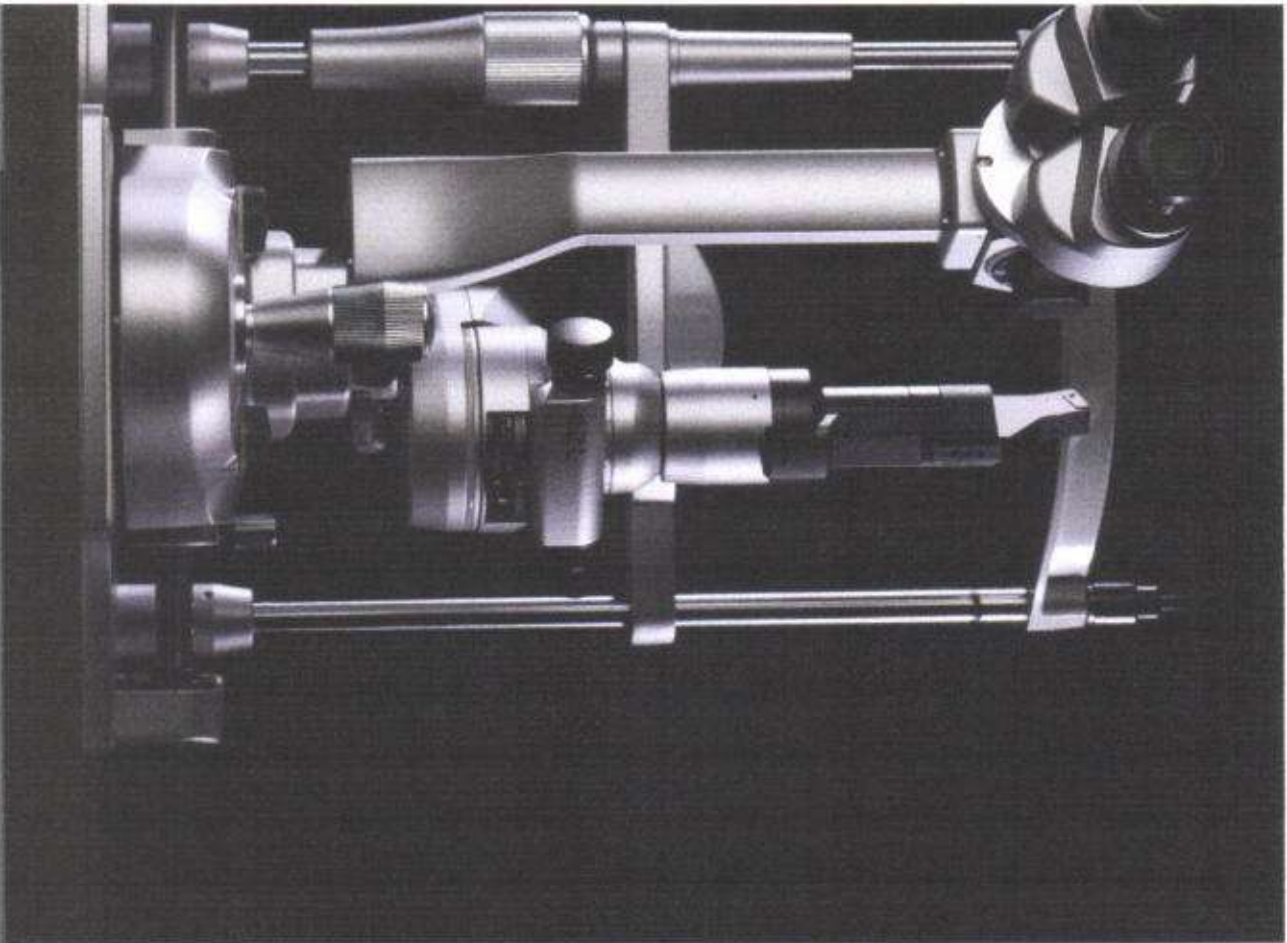

- **High-grade Slit Lamps without a cable**
- 4ZL: High-performance with a 5-step magnification changer
- 2ZL: Excellent performance with a 3-step magnification changer
- Innovative Design: No cables are exposed. Even the power supply cable is concealed.
- Even cables for connecting an imaging system can be concealed.
- New product color

LED

New LED Optimized Slit Lamp

- One of the best advantages of LED illumination is that affected anatomy and structures of the eye can now be more clearly and visibly seen because the peak wavelength of LED light appears in the region which is more sensitive to the human eye.
- We haven't simply replaced the halogen light source with an LED type. 4ZL / 2ZL have been designed and engineered from scratch to accommodate the new superior LED lamp.
- LED optimized 4ZL / 2ZL provide brighter and sharper light.

Use of Uniform LED Illumination

- The LED slit lamps with a color temperature of 3500 K provide brighter and sharper light than halogen.
- A 1-element high-luminance LED is used for 4ZL / 2ZL providing a uniform and even light compared to multiple element LED's.

Reduction of the Characteristic Blue Light of LED

- The projected light is soft and easy on patients' eyes by reducing the peak of the characteristic blue band spectrum of LED.

Optical Design

Converging Binoculars

- Binocular tubes with a 6-degree convergence provide easy binocular fusion, ensuring stress-free observation.

Usability and Ergonomics Tailored for You

Improvement of Usability

- The size, placement and other features of various controls are reconsidered based on ergonomics in order to enhance usability

Built-in Background Illumination (4ZL only)

- For use with an imaging system, the background illumination is now equipped in 4ZL as standard.
- The color balance of an image taken through 4ZL is not lost because the same LED is used for both main light source and background illumination.
- Intensity of the background illumination is adjustable by hand using the lower left hand side control.

Reduction of Patient's Inoculose

Slitlamp Microscope 2ZL



Innovative Design

- Innovative Design: No cables are exposed. Even the power supply cable is concealed.
- Even cables for connecting an imaging system can be concealed.
- New product color.

New LED Optimized Slit Lamp

- One of the best advantages of LED illumination is that affected anatomy and structures of the eye can now be more clearly and visibly seen because the peak wavelength of LED light appears in the region which is more sensitive to the human eye.
-

- We haven't simply replaced the halogen light source with an LED type. 2ZL has been designed and engineered from scratch to accommodate the new superior LED lamp.
- LED optimized 2ZL provides brighter and sharper light.

Use of Uniform LED Illumination

- The LED slit lamp with a color temperature of 3500 K provides brighter and sharper light than halogen.
- A 1-element high-luminance LED is used for 2ZL. It provides uniform and even light compared to multiple element LEDs.

Reduction of the Characteristic Blue Light of LED

- The projected light is soft and easy on patients' eyes by reducing the peak of the characteristic blue band spectrum of LED.

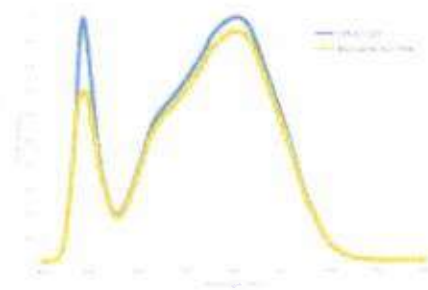

Use of Ultra-low Voltage LED

- Even though a 3-watt ultra-low voltage LED is used for 2ZL, the LED slit lamp is extremely economical while obtaining a very high level of illumination.

Affordable Precision and Reliability

- 2ZL delivers ease of use at an affordable price with ergonomic handling.
- Focussed on essential features with no compromise to our trademark precision and reliability.

Reduction of Patient's Uneasiness

- When 2ZL is switched on, a circular blue LED lights up around the lower part of the slit unit, which does not disturb the examination. The blue LED light is associated with mental calmness, reducing patient's uneasiness.
- Because the circular blue LED indicates the power is on, the users can examine with 2ZL at ease.

Specifications

Microscope	Type	Galilean converging binocular stereomicroscope
	Magnification changer	Three position rotating drum
	Eyepieces	16x wide-field, high-eyepoint
	Total magnifications	10x, 16x, 25x
	Real fields of view	φ23.3, φ14, φ8.8mm
	Interpupillary adjustment	52 - 82mm
	Diopter adjustment range	+/-7diopters
Cross-Slide Base	Longitudinal (coarse) movement	105mm
	Horizontal (fine) movement	15mm
	Vertical movement	30mm
Chinrest Unit	Elevation stroke	85mm
Illumination Unit	Slit width	0-14mm continuously variable
	Aperture	φ 14, φ 8, φ 5, φ 3, φ 0.3mm

	diaphragms	
	Filters	Blue filter, Red free filter, Blue correction filter, Yellow filter
	Light Source	LED
Power Unit	Input voltage	AC100V - 240V (+/- 10%)
	Maximum power consumption	DC5V 2A
Fixation Light Unit	Fixation light source	Red LED
Weight		11kg

Optional Components

AT-1
S12-17
Applanation
tonometer

S12-20
Tonometer Mount

S11-02 (30-70)
Beam splitter

D08-11 F=50mm
Video Camera Adaptor

S09-07SE
Assistant Scop
(short)

S11-01 (40-60)
Beam splitter

S09-08SE
Assistant Scope
(long)

S14-05
Measuring Eyepiece

S14-06
Reticule Eyepiece

S06-66
Patient's Hand Rests

S06-44
Yellow Filter

S10-17
Combination Adaptor
with Built-in Yellow Filter
F=50mm

Power Kit for Instrument
Tables (*1)

S06-59
13 degree Adaptor

For imaging devices



T0-10
Digital Camera

T0-2 Type A
Digital Camera
Adaptor

O10-105E
Titable Binocular Tail

*1 For further information on power kits, contact our Sales Department.

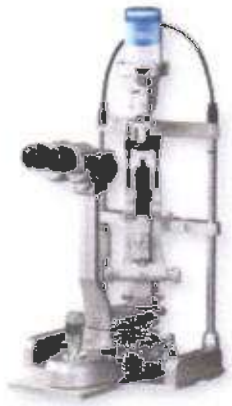

Slitlamp Microscope 700GL 700GL NSW

Serving your vision



Design

Innovative Design without a cable

- Innovative Design: No cables are exposed. Even the power supply cable is concealed.
- Conventional power cable from the chinrest to the light housing has been eliminated – now neatly concealed inside the slit lamp body.
- 700GL looks neat and compact with no exposed cables, giving a sleek look with an innovative design.
- Even cables for connecting an imaging system can be concealed.
- New product color.
- Background illumination also discreetly built in with no exposed cables.



Usability and Ergonomics Tailored for You

Improvement of Usability

The size, placement and other features of various controls are reconsidered based on ergonomics in order to enhance usability

Built-in Background Illumination

- For use with an imaging system, the background illumination is now equipped as standard.
- The color balance of an image taken through 700GL is not lost because the same LED is used for both main light source and background illumination.
- Intensity of the background illumination is adjustable by hand using the lower left hand side control.



LED



New LED Optimized Slit Lamp

- One of the best advantages of LED illumination is that affected anatomy and structures of the eye can now be more clearly and visibly seen.
- We haven't simply replaced the halogen light source with an LED type, 700GL has been designed and engineered from scratch to accommodate the new superior LED lamp.
- LED optimized 700GL provides brighter and sharper light.

Reduction of the Characteristic Blue Light of LED

- The projected light is soft and easy on patients' eyes by reducing the peak of the characteristic blue band spectrum of LED.

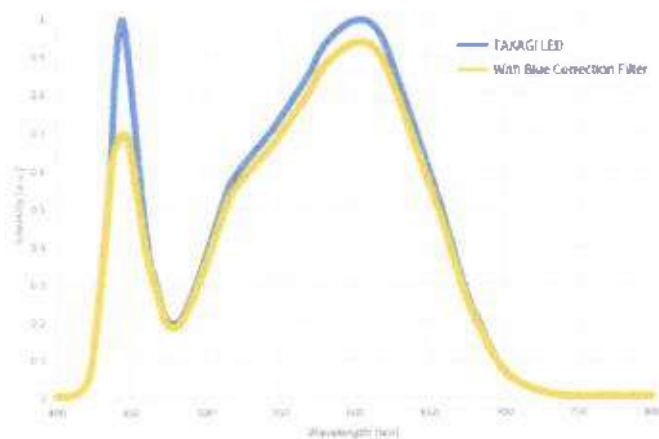

Use of Uniform LED Illumination

- The LED slit lamp with a color temperature of 3500K provides brighter and sharper light than halogen.
- A 1-element high-luminance LED is used for 700GL providing a uniform and even light compared to multiple element LED's.

Use of Low Voltage LED

- Even though a low voltage LED is used for 700GL, the LED slit lamp is extremely economical while obtaining a very high level of illumination.

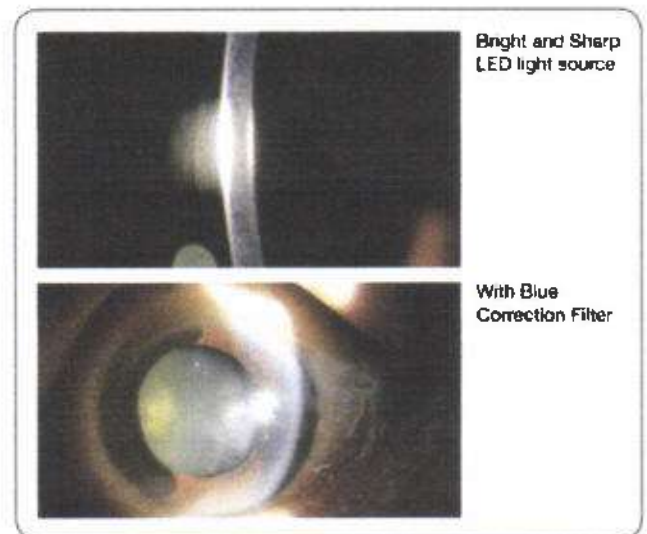



Optical Design

Clear Observation of both Anterior and Posterior Segments of the Eye

- As a result of our continuous pursuit in improving visibility of the fundus while simultaneously maintaining superior visibility of the anterior segment, the best, brightest and sharpest optical design of 700GL has been achieved.
- 700GL's binocular tubes with a 6-degree convergence provide easy binocular fusion ensuring a stress free observation.

Extended Slit Length

- The diameter of the slit length is extended to 14mm from 10mm. This allows 700GL to illuminate a wider area of the anterior segment.
- This allows 700GL to maximize its characteristics such as a wider field of view.

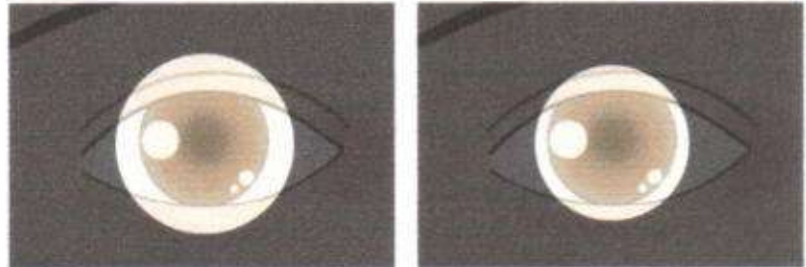

Slitlamp Microscope

700GL

Slit lamp with a feeling of being “visible”

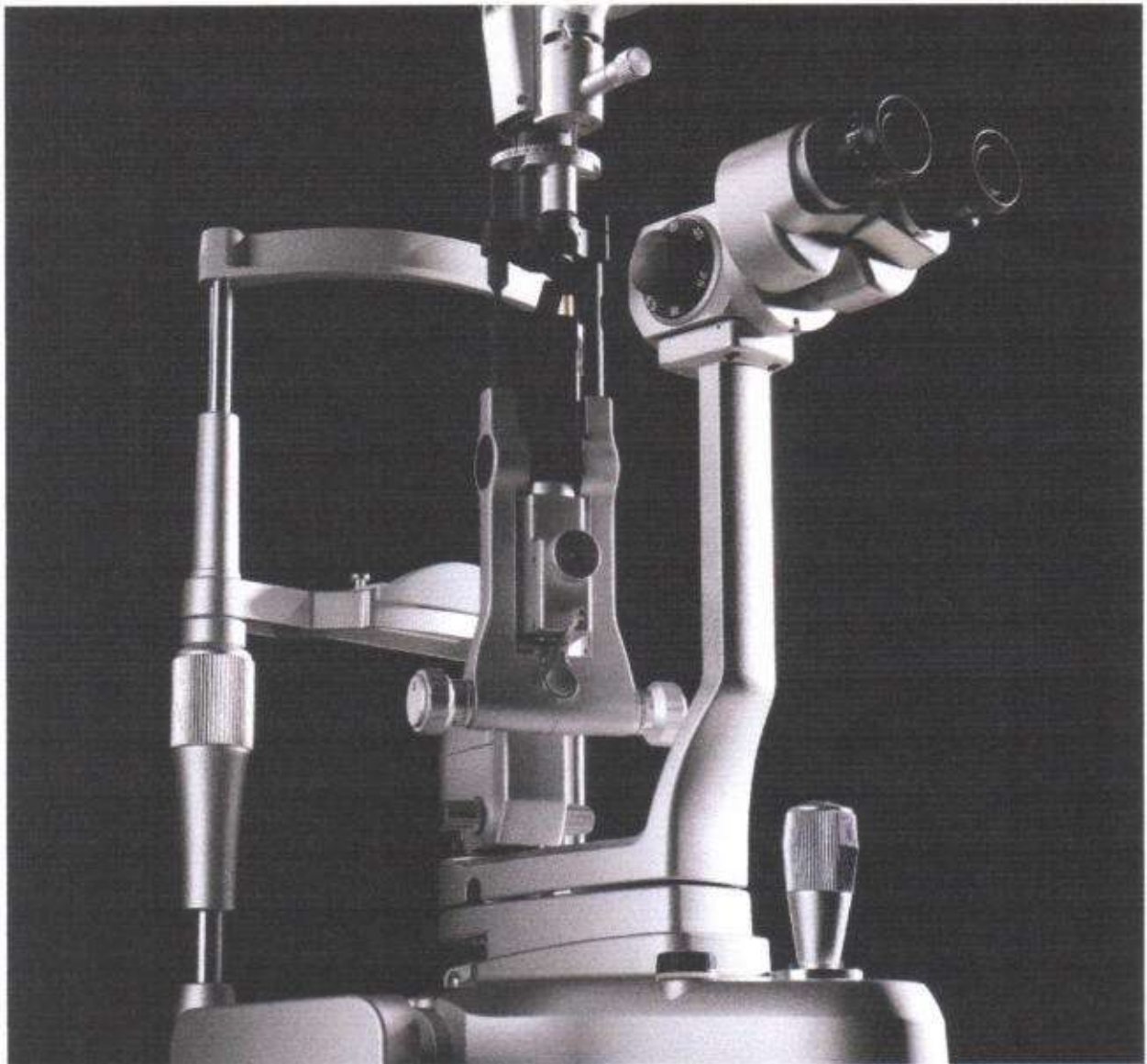

Our relentless pursuit of “visualizing” and our latest evolutionary slit lamp. Slit lamps cannot provide medical treatment, but we cannot talk about ophthalmology without slit lamps.

This slit lamp is the number one performer behind the scenes.



Major Specifications

	Model	700GL	700GL NSW
	Type	Galilean converging binocular stereomicroscope	
	Magnification change	Five-position rotating drum	
	Eyepieces	16x wide-field, high-eyepoint	12.5x wide-field, high-eyepoint
	Total magnification	6.3x, 10x, 16x, 25x, 40x	6x, 9x, 15x, 24x, 37x
Microscope	Real field of view (diameter)	35.9mm, 23.3mm, 14mm, 8.8mm, 6.6mm	37.8mm, 26.2mm, 16.1mm, 9.6mm, 6.0mm
	Convergence viewing angle	10°	12° Prism-OUT, 4.1° Prism-IN
	Eyepiece convergence	6°	6°
	Objective lens configuration	Two lens achromatic	Three lens apochromatic
	Interpupillary adjustment	52 - 62mm	
	Diopter adjustment range	+/- 7 diopters	+/- 5 diopters
Base Unit	Horizontal (coarse) movement	105mm	
	Horizontal (fine) movement	15mm	
	Vertical movement	30mm	
Chinrest Unit	Elevation stroke	65mm	
	Slit width	0-14mm continuously variable	
Illumination Unit	Aperture diaphragm (diameter)	Φ14, Φ10, Φ6, Φ3, Φ2, Φ1, Φ0.2mm	
	Filters	Blue filter, Red free filter, Blue correction filter, Yellow filter	
Power Unit	Light source	LED	
	Power supply	AC100V - 240V (+/- 10%)	
	Power consumption	DC5V 2A	
Fluorescent Light Unit	Fluorescent light source	Red LED	
	Background illumination	Built-in	
	Weight	12.5kg	13kg

Dimensions

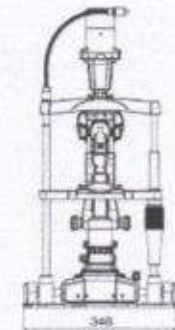
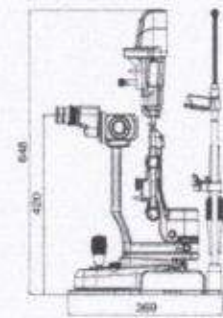

Optional Components

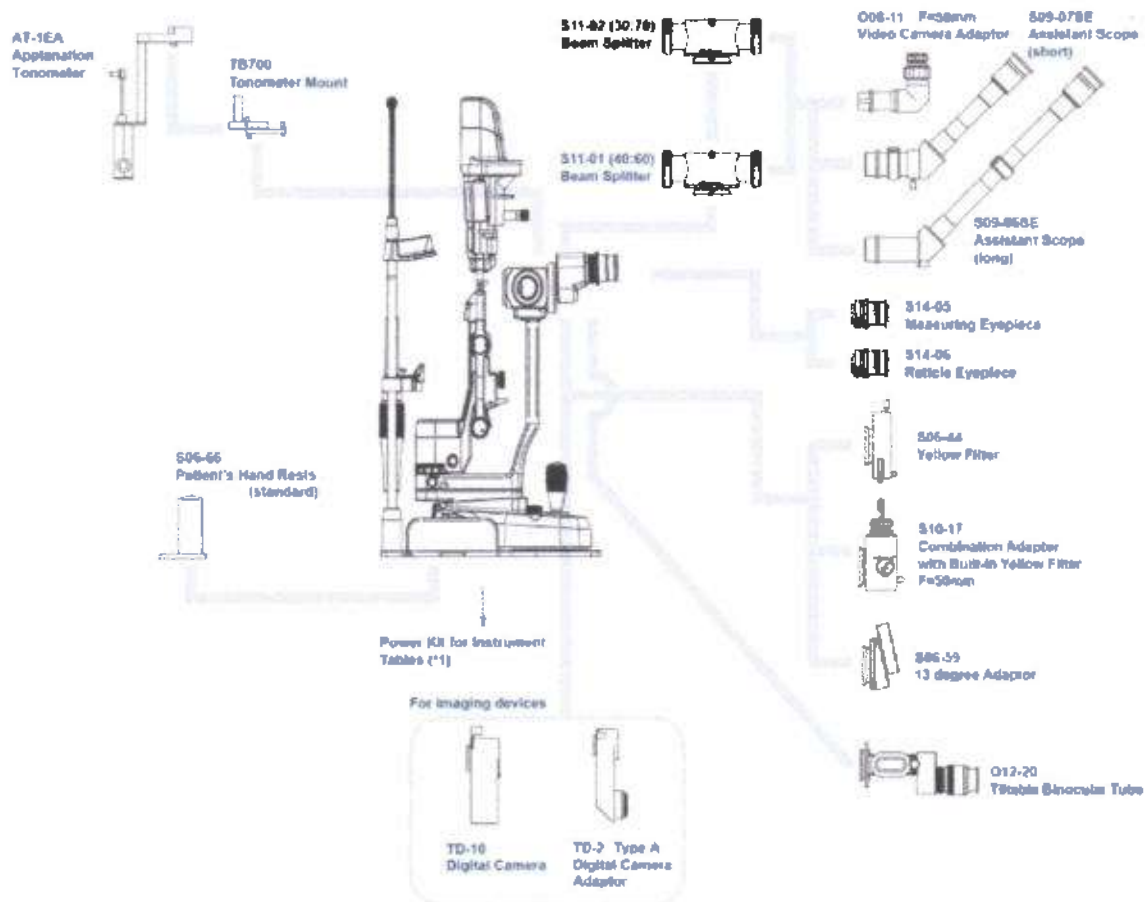

*1 For further information on power kits, contact our Sales Department.

● Design and specifications are subject to change as improvements are made to the product.

TAKAGI SEIKO CO., LTD.

330-2 IMAFUNE, NAKANO-SHI, NAGANO-KEN, 383-8585, JAPAN

TEL. +81-269-22-4512 FAX. +81-269-26-6321

URL: <http://www.takagi-j.com> E-mail: info@takagi-j.com





TAKAGI



Digital Camera & Image Filing Software TD-10 / EyeCAM

S e r v i n g y o u r v i s i o n

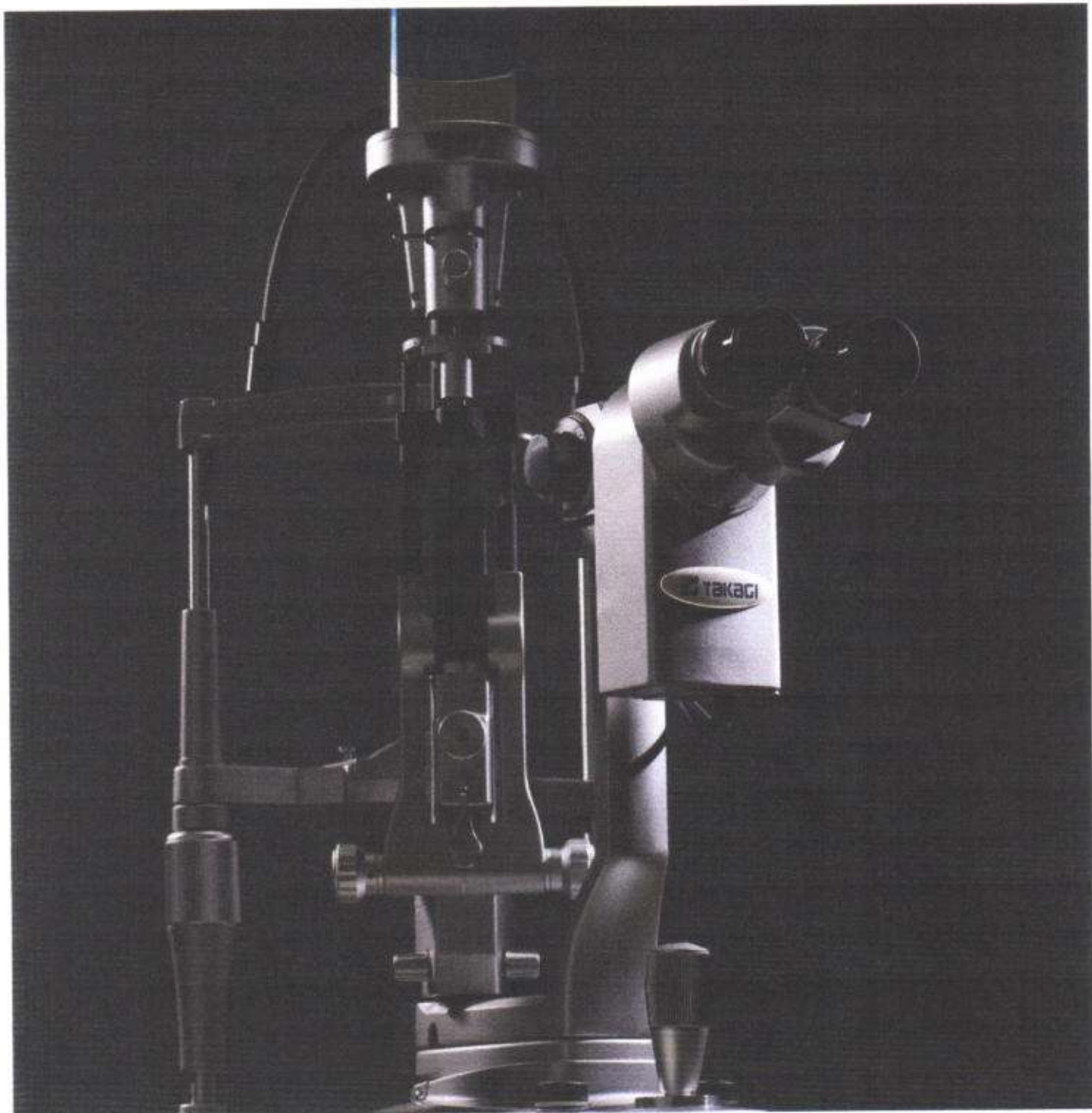

Digital Camera & Image Filing Software

TD-10 / EyeCAM

User-friendly ultra-high resolution digital imaging system with USB 3.0 connection and DICOM compatibility, realized with simple operation in combination with TD-10 digital camera and EyeCAM image & video filing software

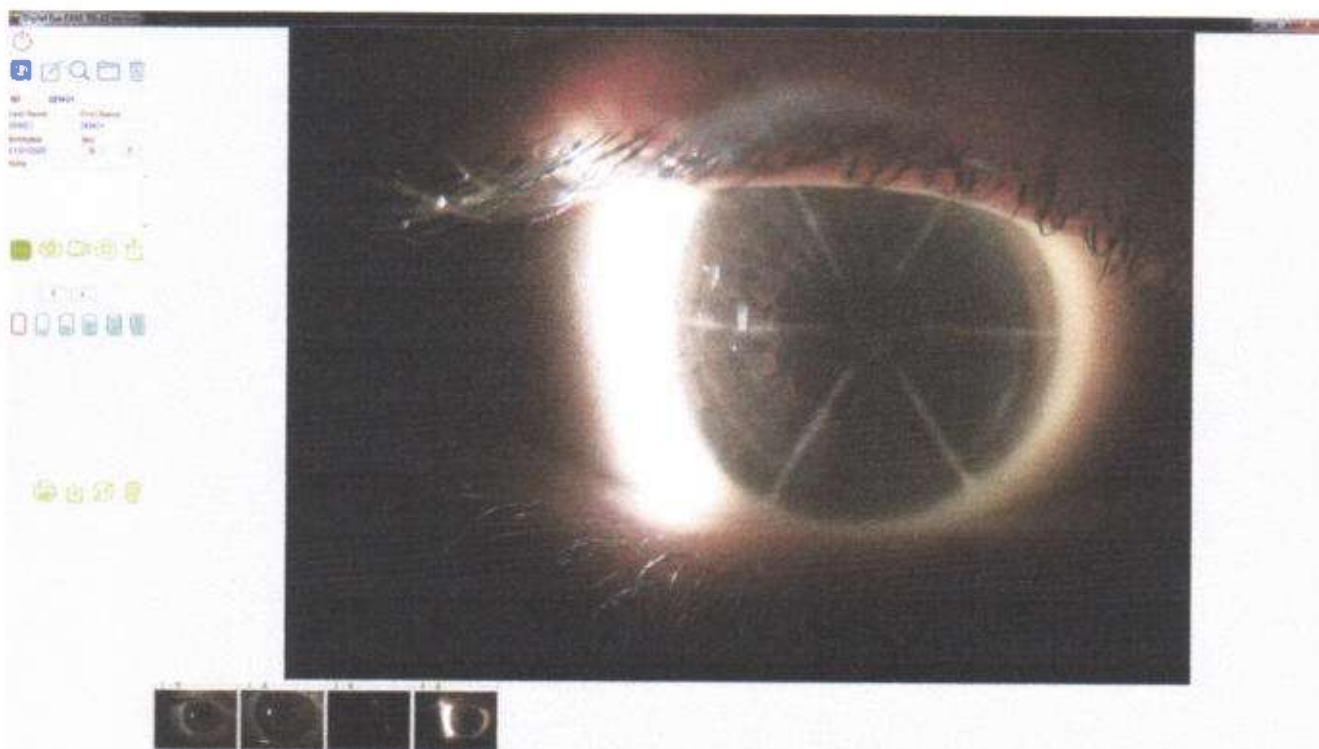

The captured image is created by inlay.

Use of Ultra High Resolution 10.7 Mega Pixel Camera

Use of Ultra High Resolution 10.7 Mega Pixel Camera with 3856 x 2764 picture size, delivering 7.4 times higher-resolution compared to the previous digital camera of TD-1plus.

USB 3.0 Connection Interface

By changing to the new USB 3.0 interface, data transfer speed is now approximately 6.4 times faster than that of the previous IEEE1394b fire-wire interface. Stress-free high-resolution live images are made possible.

User Friendly Software with DICOM Compatibility

User friendly software with patient database, full image editing facility, and DICOM compatibility.

1

Neat Digital Imaging System with hidden cables

In combination with our LED slit lamps minimum cables for TD-10 are exposed as they can be quickly and neatly concealed in the slit lamp's arm.



2

Yellow Filter Built in as Standard

High-contrast images are easily obtained by using the built-in yellow filter for corneal fluorescein observation. In conjunction with our slit lamps cobalt blue filter even higher-contrast images can be achieved.



3

Capturing of Still Images with One Push

In combination with our supplied trigger cable, still images can be captured instantly and conveniently by pressing the joystick button of the slit lamp. Captured images can be displayed as thumbnail images in the lower part of the screen for evaluation.



4

New EyeCAM Main Screen Design

The conventional image filing software & patient database have been further upgraded for more ease of use and intuitive handling by reviewing each icon while maintaining the convenient functionality.



5

Easy Capture with Six Pre-stored Eye Settings

Setting of the digital camera can be changed and saved easily with six types of scene files according to the eye condition and image type required. Use our presaved recommended settings or simply adjust each pre-set to your own desired level for very fast and convenient high quality image acquisition.

6

Convenient Comparison Functions for Follow-up Observations

Newly captured images and images taken in past examinations can be displayed on the same screen. Up to six images can be displayed and compared at once.



Camera specifications

Picture size	3856 x 2764
Resolution depth	12 bit
Digital Interface	USB 3.0
Frame Rate	28 fps
Electricity Consumption	Less than 4.5W

System Requirements

OS	Windows 7 & 8, 64bit (All Editions)
RAM	4GB or more recommended
Interface	USB 3.0
CPU	Intel i6 or superior CPU recommended

Dimensions

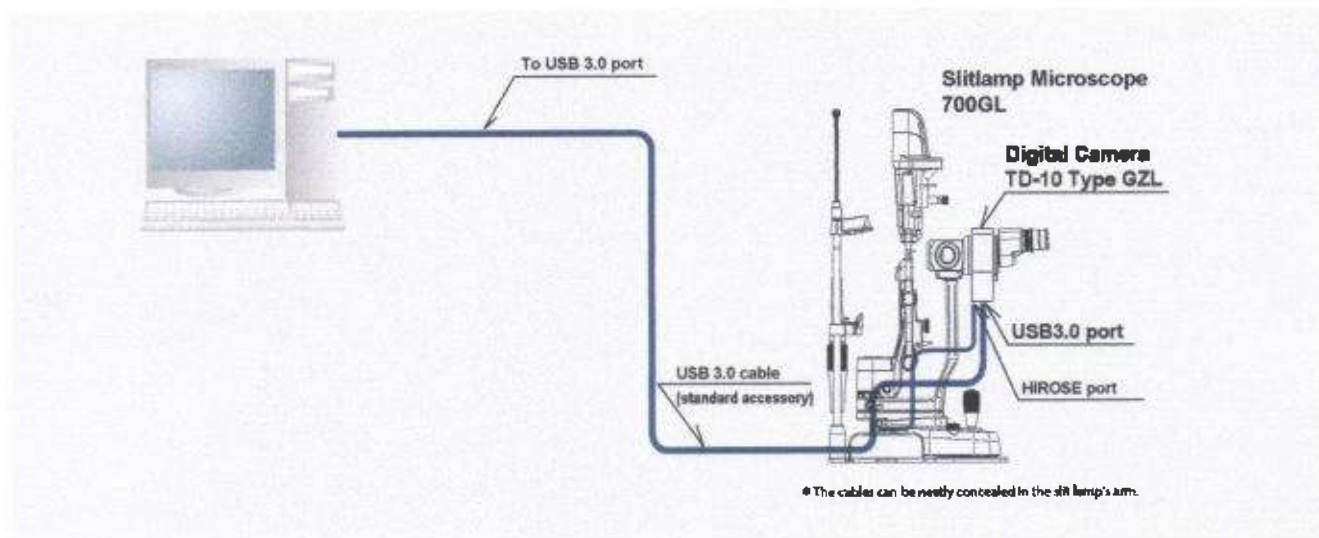
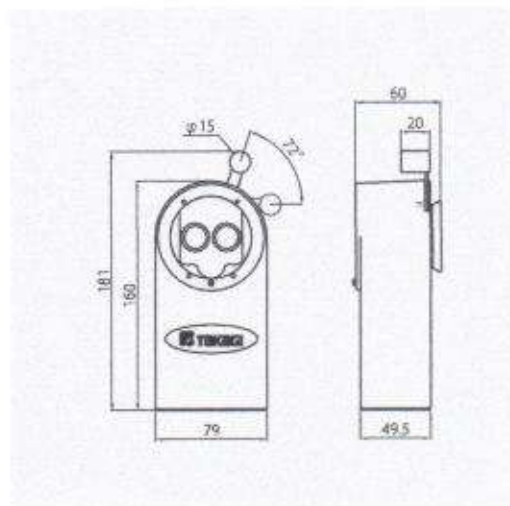

Combination with background illumination system

In combination with our background illumination device, a more comprehensive explanation is made possible to the patient.

* Back ground illumination built in as standard with 700GL and 4ZL models

Slitlamp models compatible with TD-10 types

Compatible models	Type GZL	700GL, 2ZL, 4ZL
	Type XL	300XL



● Design and specifications are subject to change as improvements are made to the product.

TAKAGI SEIKO CO.,LTD.

330-2 IWAFUNE, NAKANO-SHI, NAGANO-KEN, 383-8585, JAPAN
 TEL.+81-269-22-4512 FAX.+81-269-26-6321
 URL:<http://www.takagi-j.com> E-mail:info@takagi-j.com

