



# CV. VENUS JAYA ABADI

**ELEVATOR – TRAVELATOR – ESCALATOR – DUMBWAITER  
MAINTENANCE – INSTALLATION – MODERNIZE – REPAIR OVERHAUL**

Address : Jl.Raya Palrejo No.75 KM : 70 Desa Palrejo Sumobito Jombang

Telp/hp : 0822-3380-5999 / 0856-3049-133

email : [setiawandjodi99@gmail.com](mailto:setiawandjodi99@gmail.com) / [Venusiavaabadi646@gmail.com](mailto:Venusiavaabadi646@gmail.com)

RECEIPT NO. 107/KW/JA/III/2023

**Received from**

Rumah Sakit Mata Undaan

*Sudah Terima dari*

Jl Undaan Kulon No.19

Surabaya

**The Sum of**

Satu juta seratus sepuluh ribu rupiah

*Sejumlah*

**In Payment**

Biaya Pemeliharaan berkala 1 (satu) unit Passenger Elevator di gedung Rumah Sakit Mata Undaan Surabaya  
untuk periode bulan **Februari 2023**

*Untuk Pembayaran*

Harga tersebut sudah termasuk PPN 11%

Pembayaran di transfer via Bank BNI cabang Jombang Rek 1320563155 an. CV. VENUS JAYA ABADI

Rp

1,110,000

Jombang, 06 Maret 2023



Note / Catatan :

Payment with cheque / giroe is valid when it's cleared

*Pembayaran dengan cek / giro di nyatakan lunas jika sudah cair*

( ANANG WAHYU. S )



# CV. VENUS JAYA ABADI

ELEVATOR – TRAVELATOR – ESCALATOR – DUMBWAITER  
MAINTENANCE – INSTALLATION – MODERNIZE – REPAIR OVERHAUL

Address : Jl. Raya Palrejo No.75 KM : 70 Desa Palrejo Sumobito Jombang /  
Penjaringan Sari L24 , Jl Penjaringan Sari Rungkut Surabaya  
Telp/hp : 0822-3380-5999 / 0856-3049-133  
email : setiawandjodj99@gmail.com / Venusjayaabadi646@gmail.com

## INVOICE

Kepada Yth :

Rumah Sakit Mata Undaan

Jl Undaan Kulon No.19

Semarang

Tanggal : 07 Maret 2023

Invoice No. : 107/VJA/III/23

Bagian : Keuangan

Untuk barang - barang / pekerjaan di bawah ini :

1	Biaya Pemeliharaan berkala 1 (satu) unit Passenger Elevator di gedung Rumah Sakit Mata Undaan Surabaya , untuk periode bulan Februari 2023		Rp	1,000,000
	Total biaya sebesar	Rp	1,000,000	
	Biaya PPN 11% sebesar	Rp	110,000	
	Total Pembayaran		Rp	1,110,000

Terbilang :

Satu juta seratus sepuluh ribu rupiah

Jika pembayaran dilakukan dengan Cheque, Giro, Wesel dan sebagainya, maka hutang baru lunas setelah surat - surat berharga tersebut di tunaikan atau diterima baik oleh Bank

Jombang, 07 - 03 - 2023



ANANG WAHYU. S

Direktur

9/07/23  
A

# Faktur Pajak

Kode dan Nomor Seri Faktur Pajak : 010.003-23.86580424		
Pengusaha Kena Pajak		
Nama : CV VENUS JAYA ABADI Alamat : DSN PALREJO RT 002 RW 003 , KAB. JOMBANG NPWP : 76.984.929.0-602.000		
Pembeli Barang Kena Pajak / Penerima Jasa Kena Pajak		
Nama : PERS PERHIMPUNAN PERAWATAN PENDERITA PENYAKIT MATA Alamat : JL UNDAAN KULON Blok - No.19 RT:000 RW:000 Kel.PENELEH Kec.GENTENG Kota/Kab.SURABAYA JAWA TIMUR 00000 NPWP : 01.479.766.6-611.000		
No.	Nama Barang Kena Pajak / Jasa Kena Pajak	Harga Jual/Penggantian/Uang Muka/Termin
1	Biaya Pemeliharaan rutin 1 (satu) unit Elevator di gedung Rumah Sakit Mata Undaan Surabaya untuk periode bulan Februari 2023 Rp 1.000.000 x 1	1.000.000,00
Harga Jual / Penggantian		1.000.000,00
Dikurangi Potongan Harga		0,00
Dikurangi Uang Muka		0,00
Dasar Pengenaan Pajak		1.000.000,00
Total PPN		110.000,00
Total PPnBM (Pajak Penjualan Barang Mewah)		0,00

Sesuai dengan ketentuan yang berlaku, Direktorat Jenderal Pajak mengatur bahwa Faktur Pajak ini telah ditandatangani secara elektronik sehingga tidak diperlukan tanda tangan basah pada Faktur Pajak ini.

KAB. JOMBANG, 06 Maret 2023



ANANG WAHYU SETYAWAN



# CV. VENUS JAYA ABADI

ELEVATOR – TRAVELATOR – ESCALATOR – DUMBWAITER  
 MAINTENANCE – INSTALLATION – MODERNIZE – REPAIR OVERHAUL

Address : Jl. Raya Palrejo No. 75 KM : 70 Desa Palrejo Sumobito Jombang

Telp/Hp : 0822-3380-5999 / 0856-3049-133

email : setiawandjodi99@gmail.com / venusjayaabadi646@gmail.com

Project No	: -
Project Name	: RS Negeri Jombang
Spec/System	:
Car No	:
Type Elevator	: Passenger/Service/Bed/.....

Tanggal	: 4-2-2023
Start	:
Finish	:
Service Ke	: T. S. S. S.
Status	: FM / KS / .....

No.	Check Point	Kondisi	Periodik	Keterangan
<b>1. MACHINE ROOM</b>				
1.1	Kondisi Ruang Mesin	A. B. C.	2 Mingguan	
1.2	Lampu/Fan/AC	A. B. C.	2 Mingguan	
1.3	T/M Handle	A. B. C.	2 Mingguan	
1.4	MCB/NFB Kontrol Panel	A. B. C.	2 Mingguan	
1.5	Gear	A. B. C.	3.6.9.12	
1.6		Sheave	A. B. C.	1.7
		Rotary Mesin	A. B. C.	3.6.9.12
1.7	Traction Machine	Bearing	A. B. C.	1.7
1.8	Brake	A. B. C.	2 Mingguan	
1.9		Gear Oil	A. B. C.	2 Mingguan
1.10		Motor	A. B. C.	2 Mingguan
1.11	Care Governor	A. B. C.	3.9	
1.12	Kondisi Control Panel	A. B. C.	2 Mingguan	
<b>2. ARD</b>				
2.1	Run	A. B. C.	2 Mingguan	
2.2	Batery	A. B. C.	2 Mingguan	
<b>3. IN CAR</b>				
3.1	Kondisi Car Wall & Ceiling	A. B. C.	2.5.8.11	
3.2	Gate Switch	A. B. C.	2 Mingguan	
3.3	Open & Close Limit Sensor	A. B. C.	2 Mingguan	
3.4	Safety Edge/Ray/Beam	A. B. C.	2 Mingguan	
3.5	OPB Button, OPB S/W & Indikator	A. B. C.	2 Mingguan	
3.6	Interphone	A. B. C.	2 Mingguan	
3.7	Emergency Lamp	A. B. C.	2 Mingguan	
3.8	Kelurusan Sill Hall thdp Sill Car	A. B. C.	2 Mingguan	
<b>4. ON CAR</b>				
4.1	Emergency Exit Switch	A. B. C.	2 Mingguan	
4.2	Car Door Operator	A. B. C.	2 Mingguan	
4.3	Jarak Threshold ke Header	A. B. C.	2 Mingguan	
4.4	Top Car Emcy Stop	A. B. C.	2 Mingguan	
4.5	Sheave	A. B. C.	5.11	

No.	Check Point	Kondisi	Periodik	Keterangan
<b>4. ON CAR</b>				
4.6	Gov Rope & Safety	A. B. C.	2 Mingguan	
4.7	Switch Guide Roller & Shoe	A. B. C.	3.6.9.12	
4.8	Main Rope	A. B. C.	4.10	
4.9	CWT Weight	A. B. C.	6	
4.10	Guide Rail & Bracket	A. B. C.	8	
4.11	Oil Rail	A. B. C.	2 Mingguan	
4.12	CWT Sheave	A. B. C.	5.11	
4.13	Top Limit Switch	A. B. C.	3.6.9.12	
4.14	Hatch Door & Sill	A. B. C.	2 Mingguan	
4.15	Door Interlock Switch	A. B. C.	2 Mingguan	
4.16	Hanger Case	A. B. C.	2.5.8.11	
4.17	T-Cable	A. B. C.	4.10	
4.18	Kondisi Hoistway	A. B. C.	8	
<b>5. HALL PART</b>				
5.1	Hall Button & Indikator	A. B. C.	2 Mingguan	
5.2	Hatch Doot Key	A. B. C.	3.6.9.10	
<b>6. PIT</b>				
6.1	Pit Switch & Lampu	A. B. C.	2 Mingguan	
6.2	Buffer & Switch	A. B. C.	1.4.7.10	
6.3	Gov. Roppe & Tension Sheave	A. B. C.	4.10	
6.4	Kondisi Pit	A. B. C.	2 Mingguan	
6.5	Down Limit Switch	A. B. C.	1.4.7.10	
6.6	Sheave Bawah Car	A. B. C.	5.11	
6.7	Compen Chain, Rope & Switch	A. B. C.	1.7	
6.8	CWT Run By	A. B. C.	1.7	
6.9	T-Cable Hanger	A. B. C.	3.9	
6.10	Over Load Switch	A. B. C.	2 Mingguan	
<b>7. OPTIONAL</b>				
7.1	FER Switch	A. B. C.	2 Mingguan	
7.2	RMS System/SUPERVISORY	A. B. C.	2 Mingguan	
7.3	Lain-lain	A. B. C.	2 Mingguan	

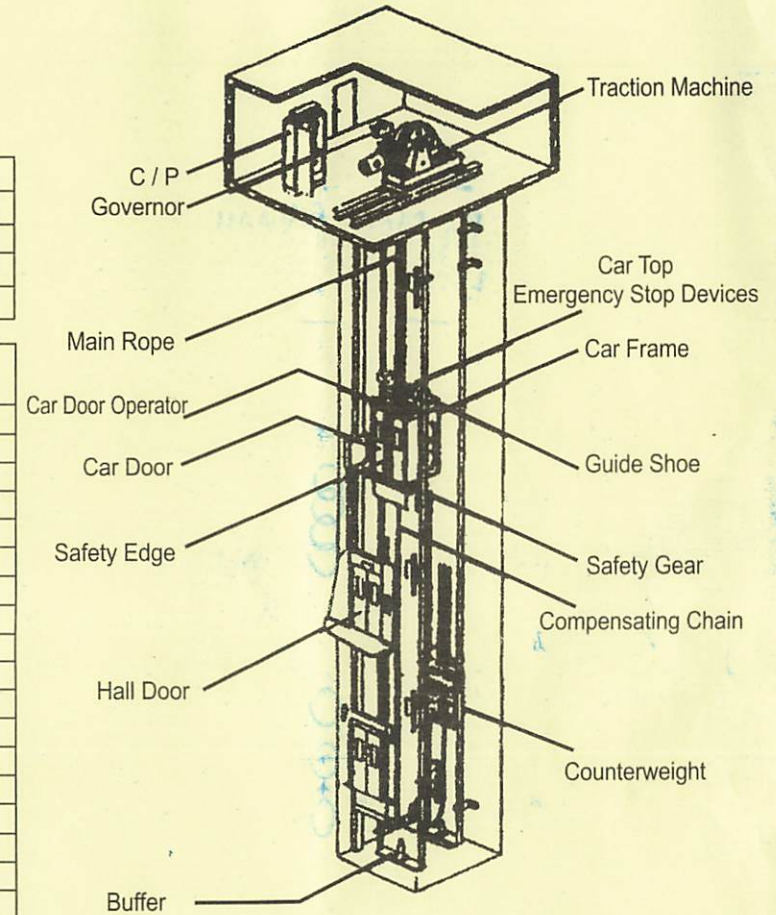

CV. VENUS JAYA ABADI

Petugas Service

Teknisi Maintenance

Mengetahui  
Pemilik / Owner

1. *Petugas Service*
2. *Teknisi Maintenance*
3. *Mengetahui Pemilik / Owner*

( ..... ) ( ..... )

Keterangan : Lingkari ( O ) Jika ;

A : Bagus

B : Perlu Perhatian

C : Rusak , Harus diperbaiki / Diganti



# CV. VENUS JAYA ABADI

ELEVATOR - TRAVELATOR - ESCALATOR - DUMBWAITER  
MAINTENANCE - INSTALLATION - MODERNIZE - REPAIR OVERHAUL

Address : Jl. Raya Palrejo No. 75 KM : 70 Desa Palrejo Sumobito Jombang  
Telp/Hp : 0822-3380-5999 / 0856-3049-133

email : setiawandjodi99@gmail.com / venusjayaabadi646@gmail.com

Project No	: -
Project Name	: RS PLATA UNDAAN
Spec/System	:
Car No	:
Type Elevator	: Passenger/Service/Bed/.....

Tanggal	: 13 2 2023
Start	:
Finish	:
Service Ke	: 11 < dms
Status	: FM / KS / .....

No.	Check Point	Kondisi	Periodik	Keterangan
<b>1. MACHINE ROOM</b>				
1.1	Kondisi Ruang Mesin	A. B. C.	2 Mingguan	
1.2	Lampu/Fan/AC	A. B. C.	2 Mingguan	
1.3	T/M Handle	A. B. C.	2 Mingguan	
1.4	MCB/NFB Kontrol Panel	A. B. C.	2 Mingguan	
1.5	Gear	A. B. C.	3.6.9.12	
1.6		Sheave	A. B. C.	1.7
		Rotary Mesin	A. B. C.	3.6.9.12
1.7	Traction Machine	A. B. C.	1.7	
1.8	Brake	A. B. C.	2 Mingguan	
1.9		Gear Oil	A. B. C.	2 Mingguan
1.10		Motor	A. B. C.	2 Mingguan
1.11	Care Governor	A. B. C.	3.9	
1.12	Kondisi Control Panel	A. B. C.	2 Mingguan	
<b>2. ARD</b>				
2.1	Run	A. B. C.	2 Mingguan	
2.2	Batery	A. B. C.	2 Mingguan	
<b>3. IN CAR</b>				
3.1	Kondisi Car Wall & Ceiling	A. B. C.	2.5.8.11	
3.2	Gate Switch	A. B. C.	2 Mingguan	
3.3	Open & Close Limit Sensor	A. B. C.	2 Mingguan	
3.4	Safety Edge/Ray/Beam	A. B. C.	2 Mingguan	
3.5	OPB Button, OPB S/W & Indikator	A. B. C.	2 Mingguan	
3.6	Interphone	A. B. C.	2 Mingguan	
3.7	Emergency Lamp	A. B. C.	2 Mingguan	
3.8	Kelurusan Sill Hall thdp Sill Car	A. B. C.	2 Mingguan	
<b>4. ON CAR</b>				
4.1	Emergency Exit Switch	A. B. C.	2 Mingguan	
4.2	Car Door Operator	A. B. C.	2 Mingguan	
4.3	Jarak Threshold ke Header	A. B. C.	2 Mingguan	
4.4	Top Car Emcy Stop	A. B. C.	2 Mingguan	
4.5	Sheave	A. B. C.	5.11	

No.	Check Point	Kondisi	Periodik	Keterangan
<b>4. ON CAR</b>				
4.6	Gov Rope & Safety	A. B. C.	2 Mingguan	
4.7	Switch Guide Roller & Shoe	A. B. C.	3.6.9.12	
4.8	Main Rope	A. B. C.	4.10	
4.9	CWT Weight	A. B. C.	6	
4.10	Guide Rail & Bracket	A. B. C.	8	
4.11	Oil Rail	A. B. C.	2 Mingguan	
4.12	CWT Sheave	A. B. C.	5.11	
4.13	Top Limit Switch	A. B. C.	3.6.9.12	
4.14	Hatch Door & Sill	A. B. C.	2 Mingguan	
4.15	Door Interlock Switch	A. B. C.	2 Mingguan	
4.16	Hanger Case	A. B. C.	2.5.8.11	
4.17	T-Cable	A. B. C.	4.10	
4.18	Kondisi Hoistway	A. B. C.	8	
<b>5. HALL PART</b>				
5.1	Hall Button & Indikator	A. B. C.	2 Mingguan	
5.2	Hatch Doot Key	A. B. C.	3.6.9.10	
<b>6. PIT</b>				
6.1	Pit Switch & Lampu	A. B. C.	2 Mingguan	
6.2	Buffer & Switch	A. B. C.	1.4.7.10	
6.3	Gov. Roppe & Tension Sheave	A. B. C.	4.10	
6.4	Kondisi Pit	A. B. C.	2 Mingguan	
6.5	Down Limit Switch	A. B. C.	1.4.7.10	
6.6	Sheave Bawah Car	A. B. C.	5.11	
6.7	Compen Chain, Rope & Switch	A. B. C.	1.7	
6.8	CWT Run By	A. B. C.	1.7	
6.9	T-Cable Hanger	A. B. C.	3.9	
6.10	Over Load Switch	A. B. C.	2 Mingguan	
<b>7. OPTIONAL</b>				
7.1	FER Switch	A. B. C.	2 Mingguan	
7.2	RMS System/SUPERVISORY	A. B. C.	2 Mingguan	
7.3	Lain-lain	A. B. C.	2 Mingguan	

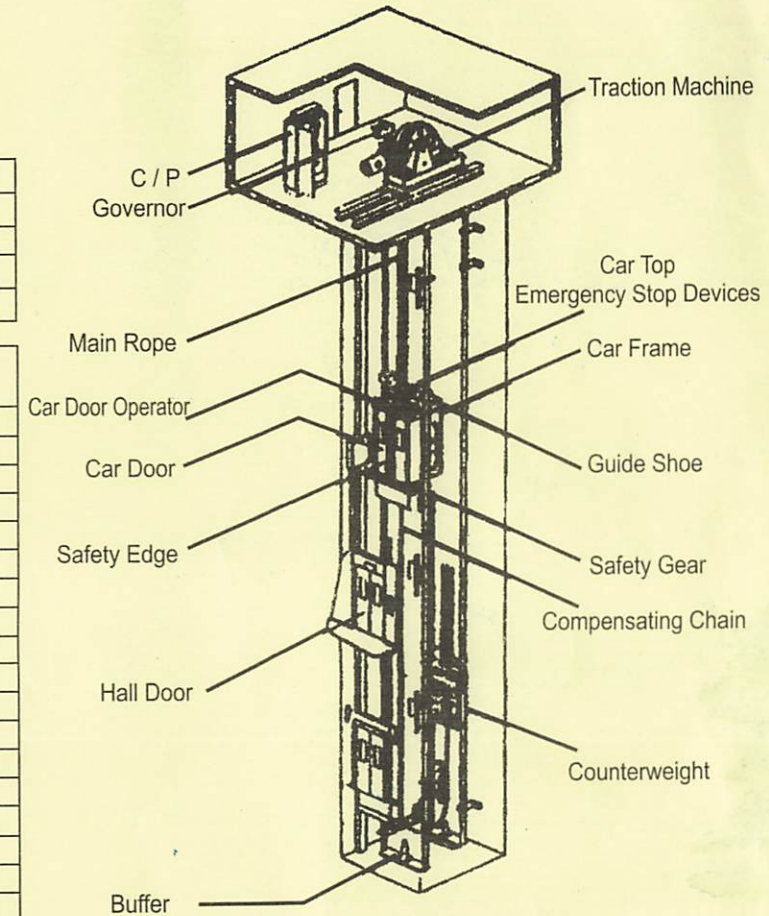

1. Buffer above 1500  
2. To below dan setting limit

## CV. VENUS JAYA ABADI

Petugas Service

Teknisi Maintenance

Mengetahui  
Pemilik / Owner

1. Fajar
2. Luthi
- 3.

( ..... ) ( ..... )

Keterangan : Lingkari ( O ) Jika ;

A : Bagus

B : Perlu Perhatian

C : Rusak , Harus diperbaiki / Diganti