



CV. VENUS JAYA ABADI

**ELEVATOR – TRAVELATOR – ESCALATOR – DUMBWAITER
MAINTENANCE – INSTALLATION – MODERNIZE – REPAIR OVERHAUL**

Address : JI. Raya Palrejo No.75 KM : 70 Desa Palrejo Sumobito Jombang /

Penjaringan Sari L24 - JI. Penjaringan Sari Rungkut - Surabaya

Telp/hp : 0822-3380-5999 / 0856-3049-133

email : sethawandjodi99@gmail.com / Venusjayaabadi646@gmail.com

RECEIPT NO. 122/KW/JA/IV/2022

Received from

Sudah Terima dari

Rumah Sakit Mata Undaan

Jl Undaan Kulon No.19

Surabaya

The Sum of

Sejumlah

Satu juta seratus sepuluh ribu rupiah

In Payment

Untuk Pembayaran

Biaya Pemeliharaan berkala 1 (satu) unit Passenger Elevator di gedung Rumah Sakit Mata Undaan Surabaya
untuk periode bulan **Maret 2022**

Harga tersebut sudah termasuk PPN 11%

Pembayaran di transfer via Bank BNI cabang Jombang Rek 1320563155 an. CV. VENUS JAYA ABADI

Rp

1,110,000

Note / Catatan :

Payment with cheque / giroe is valid when it's cleared

Pembayaran dengan cek / giro di nyatakan lunas jika sudah cair

Jombang, 04 April 2022



(ANANG WAHYU. S)



CV. VENUS JAYA ABADI

ELEVATOR – TRAVELATOR – ESCALATOR – DUMBWAITER
MAINTENANCE – INSTALLATION – MODERNIZE – REPAIR OVERHAUL

Address : Jl. Raya Palrejo No.75 KM : 70 Desa Palrejo Sumobito Jombang /
Penjaringan Sari L24 , Jl Penjaringan Sari Rungkut Surabaya
Telp/hp : 0822-3380-5999 / 0856-3049-133
email : setiawandjodi99@gmail.com / Venusjayaabadi646@gmail.com

INVOICE

Kepada Yth :

Rumah Sakit Mata Undaan

Jl Undaan Kulon No.19

Semarang

Tanggal : 04 April 2022

Invoice No. : 122/VJA/IV/22

Bagian : Keuangan

Untuk barang - barang / pekerjaan di bawah ini :

1	Biaya Pemeliharaan berkala 1 (satu) unit Passenger Elevator di gedung Rumah Sakit Mata Undaan Surabaya , untuk periode bulan Maret 2022		Rp	1,000,000
	Total biaya sebesar	Rp	1,000,000	
	Biaya PPN 11% sebesar	Rp	110,000	
	Total Pembayaran		Rp	1,110,000

Terbilang :

Satu juta seratus sepuluh ribu rupiah

Jika pembayaran dilakukan dengan Cheque, Giro, Wesel dan sebagainya, maka hutang baru lunas setelah surat - surat berharga tersebut di tunaikan atau diterima baik oleh Bank

Jombang, 04 - 04 - 2022

ANANG WAHYU. S

Direktur

Faktur Pajak

Kode dan Nomor Seri Faktur Pajak : 010.002-22.96121569

Pengusaha Kena Pajak

Nama : CV VENUS JAYA ABADI

Alamat : DSN PALREJO RT 002 RW 003 , KAB. JOMBANG

NPWP : 76.984.929.0-602.000

Pembeli Barang Kena Pajak / Penerima Jasa Kena Pajak

Nama : PERS PERHIMPUNAN PERAWATAN PENDERITA PENYAKIT MATA

Alamat : JL UNDAAN KULON Blok - No.19 RT:000 RW:000 Kel.PENELEH Kec.GENTENG Kota/Kab.SURABAYA
JAWA TIMUR 00000

NPWP : 01.479.766.6-611.000

No.	Nama Barang Kena Pajak / Jasa Kena Pajak	Harga Jual/Penggantian/Uang Muka/Termin
1	Biaya Pemeliharaan rutin 1 (satu) unit Elevator di gedung Rumah Sakit Mata Undaan Surabaya untuk periode bulan Maret 2022 Rp 1.000.000 x 1	1.000.000,00
Harga Jual / Penggantian		1.000.000,00
Dikurangi Potongan Harga		0,00
Dikurangi Uang Muka		0,00
Dasar Pengenaan Pajak		1.000.000,00
Total PPN		110.000,00
Total PPnBM (Pajak Penjualan Barang Mewah)		0,00

Sesuai dengan ketentuan yang berlaku, Direktorat Jenderal Pajak mengatur bahwa Faktur Pajak ini telah ditandatangani secara elektronik sehingga tidak diperlukan tanda tangan basah pada Faktur Pajak ini.

KAB. JOMBANG, 04 April 2022



ANANG WAHYU SETYAWAN



CV. VENUS JAYA ABADI

ELEVATOR - TRAVELATOR - ESCALATOR - DUMBWAITER
MAINTENANCE - INSTALLATION - MODERNIZE - REPAIR OVERHAUL

Address : Jl. Raya Palrejo No. 75 KM : 70 Desa Palrejo Sumobito Jombang
Telp/Hp : 0822-3380-5999 / 0856-3049-133
email : setiawandjodi99@gmail.com / venusjayaabadi646@gmail.com

Project No	:	
Project Name	:	WISATA UNDIAN
Spec/System	:	TRACCH
Car No	:	
Type Elevator	:	Passenger/Service/Bed/.....

Tanggal	:	1 - 02 - 2022
Start	:	
Finish	:	
Service Ke	:	
Status	:	FM / KS /

No.	Check Point	Kondisi	Periodik	Keterangan
1. MACHINE ROOM				
1.1	Kondisi Ruang Mesin	A. B. C.	2 Mingguan	
1.2	Lampu/Fan/AC	A. B. C.	2 Mingguan	
1.3	T/M Handle	A. B. C.	2 Mingguan	
1.4	MCB/NFB Kontrol Panel	A. B. C.	2 Mingguan	
1.5	Gear	A. B. C.	3.6.9.12	
1.6		Sheave	A. B. C.	1.7
		Rotary Mesin	A. B. C.	3.6.9.12
1.7	Traction Machine	Bearing	A. B. C.	1.7
1.8	Brake	A. B. C.	2 Mingguan	
1.9		Gear Oil	A. B. C.	2 Mingguan
1.10		Motor	A. B. C.	2 Mingguan
1.11	Care Governor	A. B. C.	3.9	
1.12	Kondisi Control Panel	A. B. C.	2 Mingguan	
2. ARD				
2.1	Run	A. B. C.	2 Mingguan	
2.2	Batery	A. B. C.	2 Mingguan	
3. IN CAR				
3.1	Kondisi Car Wall & Ceiling	A. B. C.	2.5.8.11	
3.2	Gate Switch	A. B. C.	2 Mingguan	
3.3	Open & Close Limit Sensor	A. B. C.	2 Mingguan	
3.4	Safety Edge/Ray/Beam	A. B. C.	2 Mingguan	
3.5	OPB Button, OPB S/W & Indikator	A. B. C.	2 Mingguan	
3.6	Interphone	A. B. C.	2 Mingguan	
3.7	Emergency Lamp	A. B. C.	2 Mingguan	
3.8	Kelurusan Sill Hall thdp Sill Car	A. B. C.	2 Mingguan	
4. ON CAR				
4.1	Emergency Exit Switch	A. B. C.	2 Mingguan	
4.2	Car Door Operator	A. B. C.	2 Mingguan	
4.3	Jarak Threshold ke Header	A. B. C.	2 Mingguan	
4.4	Top Car Emcy Stop	A. B. C.	2 Mingguan	
4.5	Sheave	A. B. C.	5.11	

No.	Check Point	Kondisi	Periodik	Keterangan
4. ON CAR				
4.6	Gov Rope & Safety	A. B. C.	2 Mingguan	
4.7	Switch Guide Roller & Shoe	A. B. C.	3.6.9.12	
4.8	Main Rope	A. B. C.	4.10	
4.9	CWT Weight	A. B. C.	6	
4.10	Guide Rail & Bracket	A. B. C.	8	
4.11	Oil Rail	A. B. C.	2 Mingguan	
4.12	CWT Sheave	A. B. C.	5.11	
4.13	Top Limit Switch	A. B. C.	3.6.9.12	
4.14	Hatch Door & Sill	A. B. C.	2 Mingguan	
4.15	Door Interlock Switch	A. B. C.	2 Mingguan	
4.16	Hanger Case	A. B. C.	2.5.8.11	
4.17	T-Cable	A. B. C.	4.10	
4.18	Kondisi Hoistway	A. B. C.	8	
5. HALL PART				
5.1	Hall Button & Indikator	A. B. C.	2 Mingguan	
5.2	Hatch Doot Key	A. B. C.	3.6.9.10	
6. PIT				
6.1	Pit Switch & Lampu	A. B. C.	2 Mingguan	
6.2	Buffer & Switch	A. B. C.	1.4.7.10	
6.3	Gov. Roppe & Tension Sheave	A. B. C.	4.10	
6.4	Kondisi Pit	A. B. C.	2 Mingguan	
6.5	Down Limit Switch	A. B. C.	1.4.7.10	
6.6	Sheave Bawah Car	A. B. C.	5.11	
6.7	Compen Chain, Rope & Switch	A. B. C.	1.7	
6.8	CWT Run By	A. B. C.	1.7	
6.9	T-Cable Hanger	A. B. C.	3.9	
6.10	Over Load Switch	A. B. C.	2 Mingguan	
7. OPTIONAL				
7.1	FER Switch	A. B. C.	2 Mingguan	
7.2	RMS System/SUPERVISORY	A. B. C.	2 Mingguan	
7.3	Lain-lain	A. B. C.	2 Mingguan	

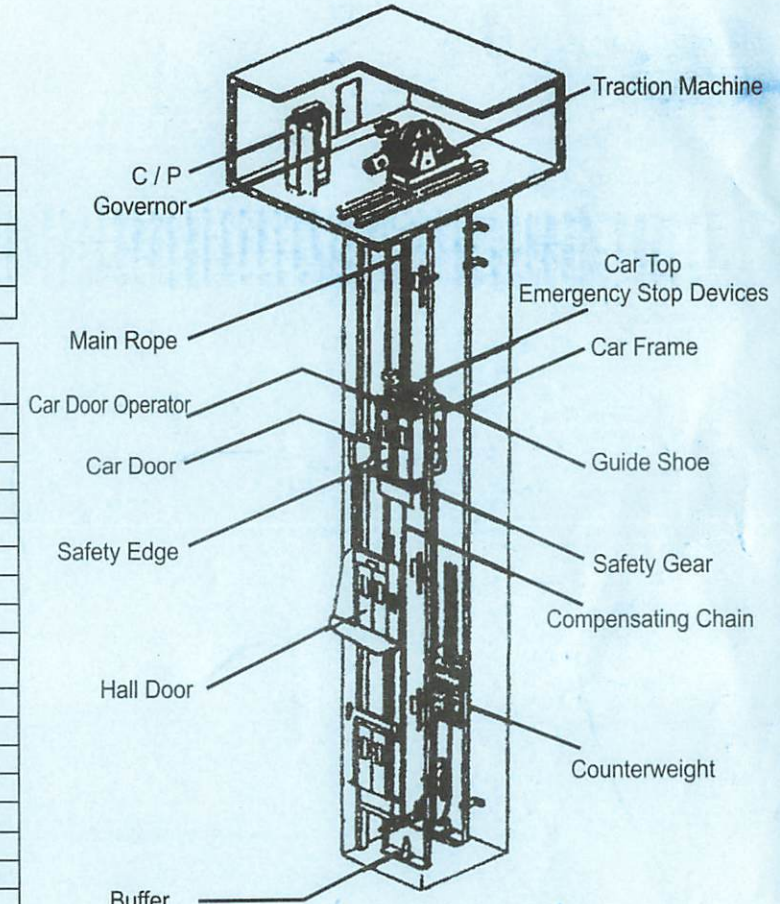

*Rope paku abnormal

CV. VENUS JAYA ABADI

Petugas Service	Teknisi Maintenance	Mengetahui Pemilik / Owner
1.		
2.		
3.		

Keterangan : Lingkari (O) Jika ; A : Bagus B : Perlu Perhatian C : Rusak , Harus diperbaiki / Diganti



CV. VENUS JAYA ABADI

ELEVATOR - TRAVELATOR - ESCALATOR - DUMBWAITER
MAINTENANCE - INSTALLATION - MODERNIZE - REPAIR OVERHAUL

Address : Jl. Raya Palrejo No. 75 KM : 70 Desa Palrejo Sumobito Jombang

Telp/Hp : 0822-3380-5999 / 0856-3049-133

email : setiawandjodi99@gmail.com / venusjayaabadi646@gmail.com

Project No	:	-
Project Name	:	RS MATA LINDAHAN
Spec/System	:	STANDARD
Car No	:	1
Type Elevator	:	Passenger/Service/Bed/.....

Tanggal	:	21 - 09 - 2022
Start	:	
Finish	:	
Service Ke	:	#
Status	:	FM / KS /

No.	Check Point	Kondisi	Periodik	Keterangan
1. MACHINE ROOM				
1.1	Kondisi Ruang Mesin	A. B. C.	2 Minggu	
1.2	Lampu/Fan/AC	A. B. C.	2 Minggu	
1.3	T/M Handle	A. B. C.	2 Minggu	
1.4	MCB/NFB Kontrol Panel	A. B. C.	2 Minggu	
1.5	Gear	A. B. C.	3.6.9.12	
1.6		Sheave	A. B. C.	1.7
		Rotary Mesin	A. B. C.	3.6.9.12
1.7	Traction Machine	Bearing	A. B. C.	1.7
1.8	Brake	A. B. C.	2 Minggu	
1.9		Gear Oil	A. B. C.	2 Minggu
1.10		Motor	A. B. C.	2 Minggu
1.11	Care Governor	A. B. C.	3.9	
1.12	Kondisi Control Panel	A. B. C.	2 Minggu	
2. ARD				
2.1	Run	A. B. C.	2 Minggu	
2.2	Batery	A. B. C.	2 Minggu	
3. IN CAR				
3.1	Kondisi Car Wall & Ceiling	A. B. C.	2.5.8.11	
3.2	Gate Switch	A. B. C.	2 Minggu	
3.3	Open & Close Limit Sensor	A. B. C.	2 Minggu	
3.4	Safety Edge/Ray/Beam	A. B. C.	2 Minggu	
3.5	OPB Button, OPB S/W & Indikator	A. B. C.	2 Minggu	
3.6	Interphone	A. B. C.	2 Minggu	
3.7	Emergency Lamp	A. B. C.	2 Minggu	
3.8	Kelurusan Sill Hall thdp Sill Car	A. B. C.	2 Minggu	
4. ON CAR				
4.1	Emergency Exit Switch	A. B. C.	2 Minggu	
4.2	Car Door Operator	A. B. C.	2 Minggu	
4.3	Jarak Threshold ke Header	A. B. C.	2 Minggu	
4.4	Top Car Emcy Stop	A. B. C.	2 Minggu	
4.5	Sheave	A. B. C.	5.11	

No.	Check Point	Kondisi	Periodik	Keterangan
4. ON CAR				
4.6	Gov Rope & Safety	A. B. C.	2 Minggu	
4.7	Switch Guide Roller & Shoe	A. B. C.	3.6.9.12	
4.8	Main Rope	A. B. C.	4.10	
4.9	CWT Weight	A. B. C.	6	
4.10	Guide Rail & Bracket	A. B. C.	8	
4.11	Oil Rail	A. B. C.	2 Minggu	
4.12	CWT Sheave	A. B. C.	5.11	
4.13	Top Limit Switch	A. B. C.	3.6.9.12	
4.14	Hatch Door & Sill	A. B. C.	2 Minggu	
4.15	Door Interlock Switch	A. B. C.	2 Minggu	
4.16	Hanger Case	A. B. C.	2.5.8.11	
4.17	T-Cable	A. B. C.	4.10	
4.18	Kondisi Hoistway	A. B. C.	8	
5. HALL PART				
5.1	Hall Button & Indikator	A. B. C.	2 Minggu	
5.2	Hatch Doot Key	A. B. C.	3.6.9.10	
6. PIT				
6.1	Pit Switch & Lampu	A. B. C.	2 Minggu	
6.2	Buffer & Switch	A. B. C.	1.4.7.10	
6.3	Gov. Roppe & Tension Sheave	A. B. C.	4.10	
6.4	Kondisi Pit	A. B. C.	2 Minggu	
6.5	Down Limit Switch	A. B. C.	1.4.7.10	
6.6	Sheave Bawah Car	A. B. C.	5.11	
6.7	Compen Chain, Rope & Switch	A. B. C.	1.7	
6.8	CWT Run By	A. B. C.	1.7	
6.9	T-Cable Hanger	A. B. C.	3.9	
6.10	Over Load Switch	A. B. C.	2 Minggu	
7. OPTIONAL				
7.1	FER Switch	A. B. C.	2 Minggu	
7.2	RMS System/SUPERVISORY	A. B. C.	2 Minggu	
7.3	Lain-lain	A. B. C.	2 Minggu	

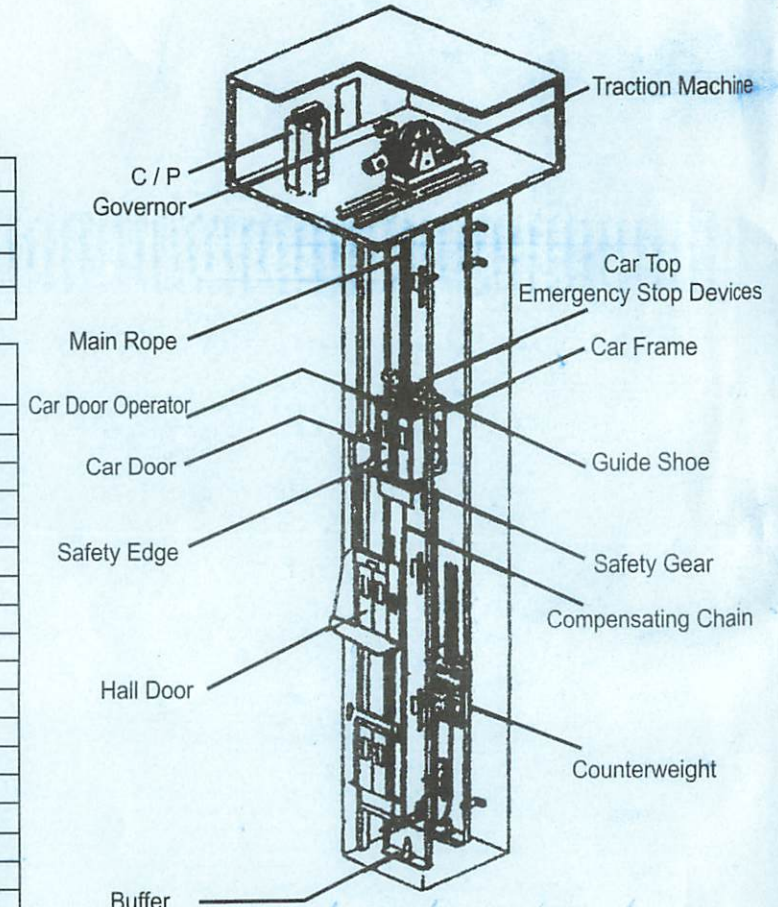

CV. VENUS JAYA ABADI

Petugas Service

Teknisi Maintenance

Mengetahui
Pemilik / Owner

1.
2.
3.

(*[Signature]*) (*[Signature]*)

Keterangan : Lingkari (O) Jika ;

A : Bagus

B : Perlu Perhatian

C : Rusak , Harus diperbaiki / Diganti