



CV. VENUS JAYA ABADI

**ELEVATOR – TRAVELATOR – ESCALATOR – DUMBWAITER
MAINTENANCE – INSTALLATION – MODERNIZE – REPAIR OVERHAUL**

Address : Jl. Raya Palrejo No.75 KM : 70 Desa Palrejo Sumobito Jombang /
Penjaringan Sari L24 - Jl. Penjaringan Sari Rungkut - Surabaya
Telp/hp : 0822-3380-5999 / 0856-3049-133
email : setiawandjodi99@gmail.com / Venusjavaabadi646@gmail.com

RECEIPT NO. 016/KW/VJA/II/2022

Received from

Rumah Sakit Mata Undaan

Sudah Terima dari

Jl Undaan Kulon No.19

Surabaya

The Sum of

Satu juta seratus ribu rupiah

Sejumlah

In Payment

Biaya Pemeliharaan berkala 1 (satu) unit Passenger Elevator di gedung Rumah Sakit Mata Undaan Surabaya
untuk periode bulan **Desember 2021**

Untuk Pembayaran

Harga tersebut sudah termasuk PPN 10%

Pembayaran di transfer via Bank BNI cabang Jombang Rek 1320563155 an. CV. VENUS JAYA ABADI

Rp

1,100,000

Note / Catatan :

Payment with cheque / giroe is valid when it's cleared

Pembayaran dengan cek / giro di nyatakan lunas jika sudah cair

Jombang, 03 Januari 2022

(ANANG WAHYU. S)



CV. VENUS JAYA ABADI

ELEVATOR – TRAVELATOR – ESCALATOR – DUMBWAITER
MAINTENANCE – INSTALLATION – MODERNIZE – REPAIR OVERHAUL

Address : Jl. Raya Palrejo No.75 KM : 70 Desa Palrejo Sumobito Jombang /

Penjaringan Sari L24 , Jl Penjaringan Sari Rungkut Surabaya

Telp/hp : 0822-3380-5999 / 0856-3049-133

email : seliawandjodi99@gmail.com / Venusjayaabadi646@gmail.com

INVOICE

Kepada Yth :

Rumah Sakit Mata Undaan

Jl Undaan Kulon No.19

Semarang

Tanggal : 03 Januari 2022

Invoice No. : 016/VJA/I/22

Bagian : Keuangan

Untuk barang - barang / pekerjaan di bawah ini :

1	Biaya Pemeliharaan berkala 1 (satu) unit Passenger Elevator di gedung Rumah Sakit Mata Undaan Surabaya , untuk periode bulan Desember 2021		Rp	1,000,000
	Total biaya sebesar	Rp	1,000,000	
	Biaya PPN 10% sebesar	Rp	100,000	
	Total Pembayaran		Rp	1,100,000

Terbilang :

Satu juta seratus ribu rupiah

Jika pembayaran dilakukan dengan Cheque, Giro, Wesel dan sebagainya, maka hutang baru lunas setelah surat - surat berharga tersebut di tunaikan atau diterima baik oleh Bank

Jombang, 03 - 01 - 2022

ANANG WAHYU. S

Direktur

Faktur Pajak

Kode dan Nomor Seri Faktur Pajak : 010.002-22.96121463		
Pengusaha Kena Pajak		
Nama : CV VENUS JAYA ABADI Alamat : DSN PALREJO RT 002 RW 003 , KAB. JOMBANG NPWP : 76.984.929.0-602.000		
Pembeli Barang Kena Pajak / Penerima Jasa Kena Pajak		
Nama : PERS PERHIMPUNAN PERAWATAN PENYAKIT MATA Alamat : JL UNDAAN KULON Blok - No.19 RT:000 RW:000 Kel.PENELEH Kec.GENTENG Kota/Kab.SURABAYA JAWA TIMUR 00000 NPWP : 01.479.766.6-611.000		
No.	Nama Barang Kena Pajak / Jasa Kena Pajak	Harga Jual/Penggantian/Uang Muka/Termin
1	Biaya Pemeliharaan rutin 1 (satu) unit Elevator di gedung Rumah Sakit Mata Undaan Surabaya untuk periode bulan Desember 2021 Rp 1.000.000 x 1	1.000.000,00
Harga Jual / Penggantian		1.000.000,00
Dikurangi Potongan Harga		0,00
Dikurangi Uang Muka		0,00
Dasar Pengenaan Pajak		1.000.000,00
PPN = 10% x Dasar Pengenaan Pajak		100.000,00
Total PPnBM (Pajak Penjualan Barang Mewah)		0,00

Sesuai dengan ketentuan yang berlaku, Direktorat Jenderal Pajak mengatur bahwa Faktur Pajak ini telah ditandatangani secara elektronik sehingga tidak diperlukan tanda tangan basah pada Faktur Pajak ini.

KAB. JOMBANG, 03 Januari 2022



ANANG WAHYU SETYAWAN



CV. VENUS JAYA ABADI

ELEVATOR - TRAVELATOR - ESCALATOR - DUMBWAITER
MAINTENANCE - INSTALLATION - MODERNIZE - REPAIR OVERHAUL

Address : Jl. Raya Palrejo No. 75 KM : 70 Desa Palrejo Sumobito Jombang

Telp/Hp : 0822-3380-5999 / 0856-3049-133

email : setiawandjodi99@gmail.com / venusjayaabadi646@gmail.com

Project No	:	-
Project Name	:	AS MATA UNDAIAN
Spec/System	:	Passenger (Mandah)
Car No	:	
Type Elevator	:	Passenger/Service/Bed/.....

Tanggal	:	13-12-2021
Start	:	
Finish	:	
Service Ke	:	
Status	:	FM / KS /

No.	Check Point	Kondisi	Periodik	Keterangan
1. MACHINE ROOM				
1.1	Kondisi Ruang Mesin	A. B. C.	2 Mingguan	
1.2	Lampu/Fan/AC	A. B. C.	2 Mingguan	
1.3	T/M Handle	A. B. C.	2 Mingguan	
1.4	MCB/NFB Kontrol Panel	A. B. C.	2 Mingguan	
1.5	Gear	A. B. C.	3.6.9.12	
1.6		Sheave	A. B. C.	1.7
		Rotary Mesin	A. B. C.	3.6.9.12
1.7	Traction Machine	A. B. C.	1.7	
1.8	Brake	A. B. C.	2 Mingguan	
1.9		Gear Oil	A. B. C.	2 Mingguan
1.10		Motor	A. B. C.	2 Mingguan
1.11	Care Governor	A. B. C.	3.9	
1.12	Kondisi Control Panel	A. B. C.	2 Mingguan	
2. ARD				
2.1	Run	A. B. C.	2 Mingguan	
2.2	Batery	A. B. C.	2 Mingguan	
3. IN CAR				
3.1	Kondisi Car Wall & Ceiling	A. B. C.	2.5.8.11	
3.2	Gate Switch	A. B. C.	2 Mingguan	
3.3	Open & Close Limit Sensor	A. B. C.	2 Mingguan	
3.4	Safety Edge/Ray/Beam	A. B. C.	2 Mingguan	
3.5	OPB Button, OPB S/W & Indikator	A. B. C.	2 Mingguan	
3.6	Interphone	A. B. C.	2 Mingguan	
3.7	Emergency Lamp	A. B. C.	2 Mingguan	
3.8	Kelurusan Sill Hall thdp Sill Car	A. B. C.	2 Mingguan	
4. ON CAR				
4.1	Emergency Exit Switch	A. B. C.	2 Mingguan	
4.2	Car Door Operator	A. B. C.	2 Mingguan	
4.3	Jarak Threshold ke Header	A. B. C.	2 Mingguan	
4.4	Top Car Emcy Stop	A. B. C.	2 Mingguan	
4.5	Sheave	A. B. C.	5.11	

No.	Check Point	Kondisi	Periodik	Keterangan
4. ON CAR				
4.6	Gov Rope & Safety	A. B. C.	2 Mingguan	
4.7	Switch Guide Roller & Shoe	A. B. C.	3.6.9.12	
4.8	Main Rope	A. B. C.	4.10	
4.9	CWT Weight	A. B. C.	6	
4.10	Guide Rail & Bracket	A. B. C.	8	
4.11	Oil Rail	A. B. C.	2 Mingguan	
4.12	CWT Sheave	A. B. C.	5.11	
4.13	Top Limit Switch	A. B. C.	3.6.9.12	
4.14	Hatch Door & Sill	A. B. C.	2 Mingguan	
4.15	Door Interlock Switch	A. B. C.	2 Mingguan	
4.16	Hanger Case	A. B. C.	2.5.8.11	
4.17	T-Cable	A. B. C.	4.10	
4.18	Kondisi Hoistway	A. B. C.	8	
5. HALL PART				
5.1	Hall Button & Indikator	A. B. C.	2 Mingguan	
5.2	Hatch Doot Key	A. B. C.	3.6.9.10	
6. PIT				
6.1	Pit Switch & Lampu	A. B. C.	2 Mingguan	
6.2	Buffer & Switch	A. B. C.	1.4.7.10	
6.3	Gov. Roppe & Tension Sheave	A. B. C.	4.10	
6.4	Kondisi Pit	A. B. C.	2 Mingguan	
6.5	Down Limit Switch	A. B. C.	1.4.7.10	
6.6	Sheave Bawah Car	A. B. C.	5.11	
6.7	Compen Chain, Rope & Switch	A. B. C.	1.7	
6.8	CWT Run By	A. B. C.	1.7	
6.9	T-Cable Hanger	A. B. C.	3.9	
6.10	Over Load Switch	A. B. C.	2 Mingguan	
7. OPTIONAL				
7.1	FER Switch	A. B. C.	2 Mingguan	
7.2	RMS System/SUPERVISORY	A. B. C.	2 Mingguan	
7.3	Lain-lain	A. B. C.	2 Mingguan	

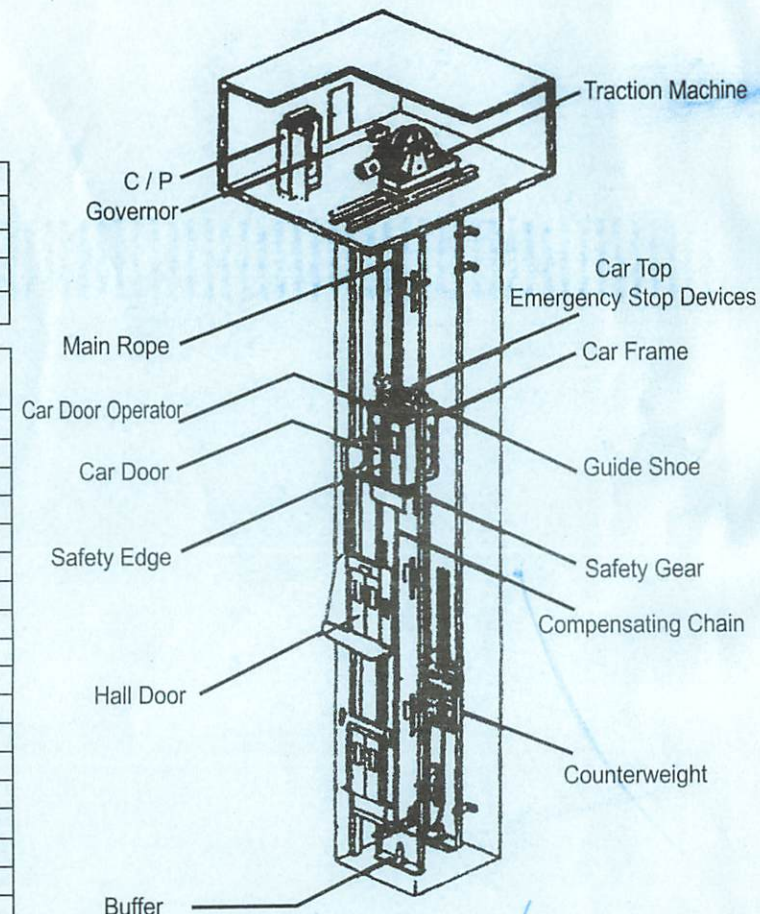

CV. VENUS JAYA ABADI

Petugas Service

Teknisi Maintenance

Mengetahui
Pemilik / Owner

- 1.
- 2.
- 3.

(.....) (.....)

Keterangan : Lingkari (O) Jika ;

A : Bagus

B : Perlu Perhatian

C : Rusak , Harus diperbaiki / Diganti



CV. VENUS JAYA ABADI

ELEVATOR - TRAVELATOR - ESCALATOR - DUMBWAITER
MAINTENANCE - INSTALLATION - MODERNIZE - REPAIR OVERHAUL

Address : Jl. Raya Palrejo No. 75 KM : 70 Desa Palrejo Sumobito Jombang

Telp/Hp : 0822-3380-5999 / 0856-3049-133

email : setiawandjodi99@gmail.com / venusjayaabadi646@gmail.com

Project No	:	-
Project Name	:	REPAIR LIFT
Spec/System	:	Passenger
Car No	:	1
Type Elevator	:	Passenger/Service/Bed/.....

Tanggal	:	27-12-2021
Start	:	
Finish	:	
Service Ke	:	TR
Status	:	FM / KS /

No.	Check Point	Kondisi	Periodik	Keterangan
1. MACHINE ROOM				
1.1	Kondisi Ruangan Mesin	A. B. C.	2 Mingguan	
1.2	Lampu/Fan/AC	A. B. C.	2 Mingguan	
1.3	T/M Handle	A. B. C.	2 Mingguan	
1.4	MCB/NFB Kontrol Panel	A. B. C.	2 Mingguan	
1.5	Gear	A. B. C.	3.6.9.12	
1.6		Sheave	A. B. C.	1.7
		Rotary Mesin	A. B. C.	3.6.9.12
1.7	Traction Machine	Bearing	A. B. C.	1.7
1.8	Brake	A. B. C.	2 Mingguan	
1.9		Gear Oil	A. B. C.	2 Mingguan
1.10		Motor	A. B. C.	2 Mingguan
1.11	Care Governor	A. B. C.	3.9	
1.12	Kondisi Control Panel	A. B. C.	2 Mingguan	
2. ARD				
2.1	Run	A. B. C.	2 Mingguan	
2.2	Batery	A. B. C.	2 Mingguan	
3. IN CAR				
3.1	Kondisi Car Wall & Ceiling	A. B. C.	2.5.8.11	
3.2	Gate Switch	A. B. C.	2 Mingguan	
3.3	Open & Close Limit Sensor	A. B. C.	2 Mingguan	
3.4	Safety Edge/Ray/Beam	A. B. C.	2 Mingguan	
3.5	OPB Button, OPB S/W & Indikator	A. B. C.	2 Mingguan	
3.6	Interphone	A. B. C.	2 Mingguan	
3.7	Emergency Lamp	A. B. C.	2 Mingguan	
3.8	Kelurusan Sill Hall thdp Sill Car	A. B. C.	2 Mingguan	
4. ON CAR				
4.1	Emergency Exit Switch	A. B. C.	2 Mingguan	
4.2	Car Door Operator	A. B. C.	2 Mingguan	
4.3	Jarak Threshold ke Header	A. B. C.	2 Mingguan	
4.4	Top Car Emcy Stop	A. B. C.	2 Mingguan	
4.5	Sheave	A. B. C.	5.11	

No.	Check Point	Kondisi	Periodik	Keterangan
4. ON CAR				
4.6	Gov Rope & Safety	A. B. C.	2 Mingguan	
4.7	Switch Guide Roller & Shoe	A. B. C.	3.6.9.12	
4.8	Main Rope	A. B. C.	4.10	
4.9	CWT Weight	A. B. C.	6	
4.10	Guide Rail & Bracket	A. B. C.	8	
4.11	Oil Rail	A. B. C.	2 Mingguan	
4.12	CWT Sheave	A. B. C.	5.11	
4.13	Top Limit Switch	A. B. C.	3.6.9.12	
4.14	Hatch Door & Sill	A. B. C.	2 Mingguan	
4.15	Door Interlock Switch	A. B. C.	2 Mingguan	
4.16	Hanger Case	A. B. C.	2.5.8.11	
4.17	T-Cable	A. B. C.	4.10	
4.18	Kondisi Hoistway	A. B. C.	8	
5. HALL PART				
5.1	Hall Button & Indikator	A. B. C.	2 Mingguan	
5.2	Hatch Doot Key	A. B. C.	3.6.9.10	
6. PIT				
6.1	Pit Switch & Lampu	A. B. C.	2 Mingguan	
6.2	Buffer & Switch	A. B. C.	1.4.7.10	
6.3	Gov. Roppe & Tension Sheave	A. B. C.	4.10	
6.4	Kondisi Pit	A. B. C.	2 Mingguan	
6.5	Down Limit Switch	A. B. C.	1.4.7.10	
6.6	Sheave Bawah Car	A. B. C.	5.11	
6.7	Compen Chain, Rope & Switch	A. B. C.	1.7	
6.8	CWT Run By	A. B. C.	1.7	
6.9	T-Cable Hanger	A. B. C.	3.9	
6.10	Over Load Switch	A. B. C.	2 Mingguan	
7. OPTIONAL				
7.1	FER Switch	A. B. C.	2 Mingguan	
7.2	RMS System/SUPERVISORY	A. B. C.	2 Mingguan	
7.3	Lain-lain	A. B. C.	2 Mingguan	

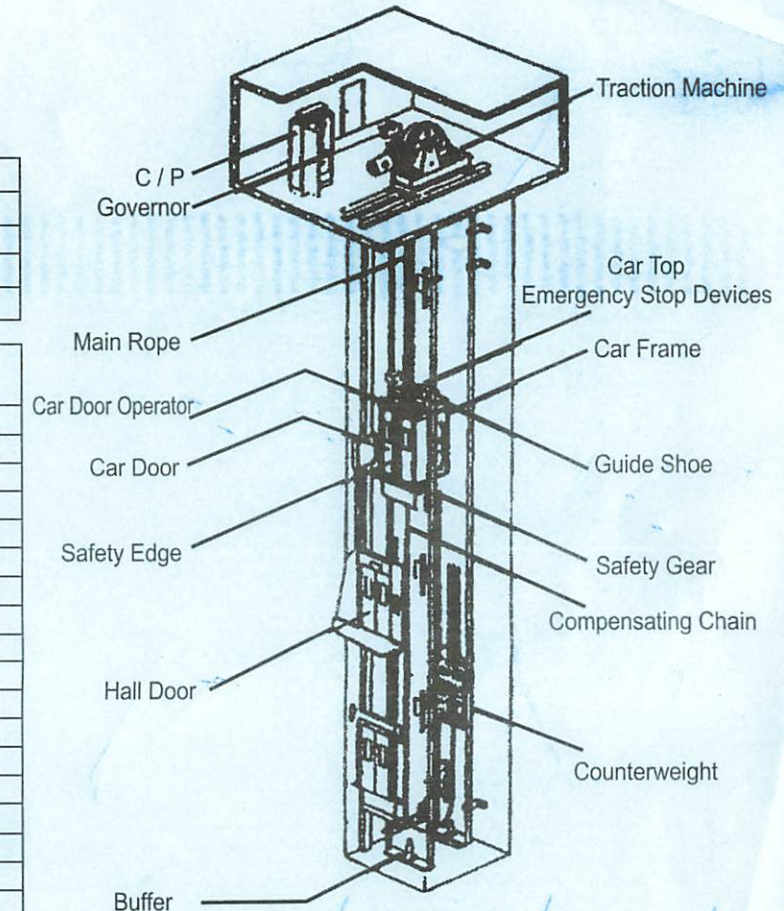

CV. VENUS JAYA ABADI

Petugas Service

Teknisi Maintenance

Mengetahui
Pemilik / Owner

- 1.
- 2.
- 3.

(.....) (.....)

Keterangan : Lingkari (O) Jika ;

A : Bagus

B : Perlu Perhatian

C : Rusak , Harus diperbaiki / Diganti